

# SUPER

A DOVER COMPANY

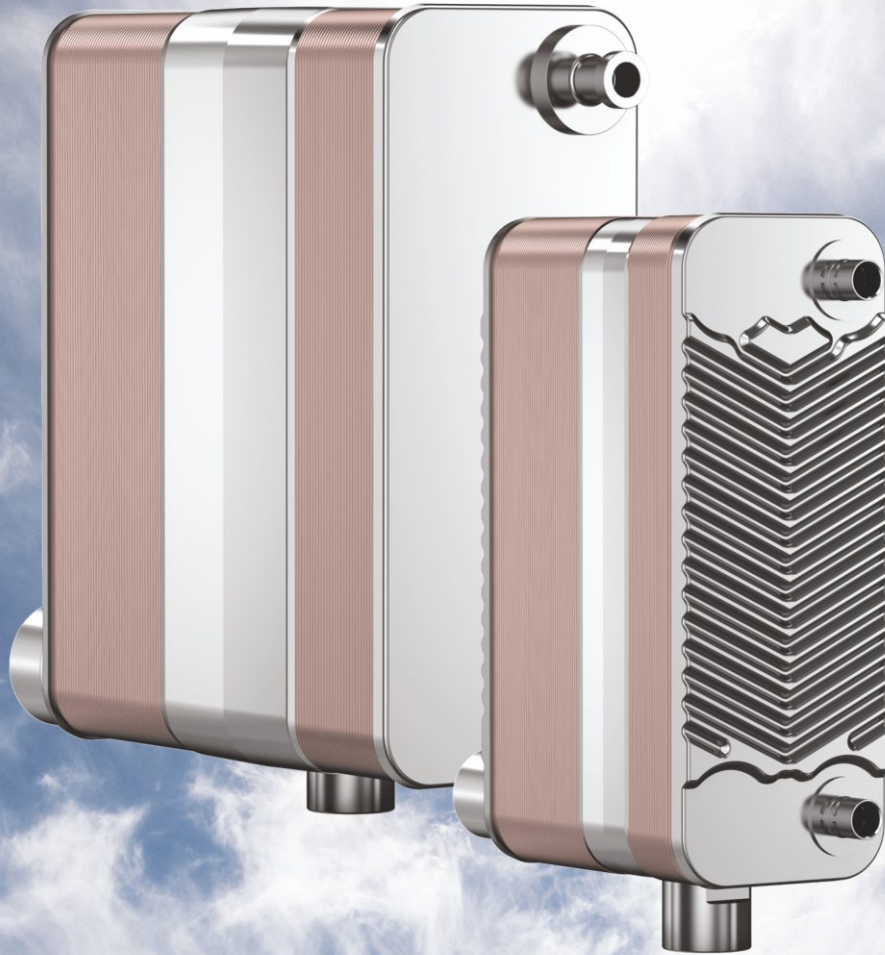

**Simplifying business**  
**Air dryer with integrated separator**

# Moisture in compressed air

Refrigerated air dryer systems are commonly used to remove moisture from compressed air. This is necessary to prevent condensation in the subsequent process, leading to costly corrosion. However, the market is demanding increasingly compact solutions, and this is the challenge that SWEP has accepted and met. SWEP's core competence is the design of compact brazed heat exchangers (BPHEs). This has been applied to create a new product range: ADWIS – Air Dryer With Integrated Separator – covering the 35-400 Nm<sup>3</sup>/h capacity range with 11 models in just two envelopes.

## The new ADWIS

While solving the theoretical and practical problems, SWEP spent several years studying various designs in close co-operation with specialist suppliers and universities. The new ADWIS concept is the result. It combines an integrated separator with a circulation system that increases efficiency by exploiting the temperature difference between two plate packages. Extensive field-testing has now proved the concept's effectiveness.

## Key advantages of ADWIS

**Breakthrough Compactness:** ADWIS has a small footprint, thanks to efficient plate design. Furthermore, the crucial height dimension is the smallest available, at only 189 mm for the ADWIS 35-100 Nm<sup>3</sup>/h envelope and 289 mm for the ADWIS 120-400 Nm<sup>3</sup>/h envelope .

**Safety:** ADWIS has PED approval, and operates safely at up to 30% above nominal capacity to cope with short-term demands for higher capacity. The design also ensures that there is no condensate in the heat exchangers, and no water remains in ADWIS when the system is off. Water is drained simply from the unit's lowest point.

**Economy:** Simple mountings and easy connection make ADWIS an economical solution. The uncomplicated envelope, free from voids and piping, facilitates installation and allows insulation to be standardized.

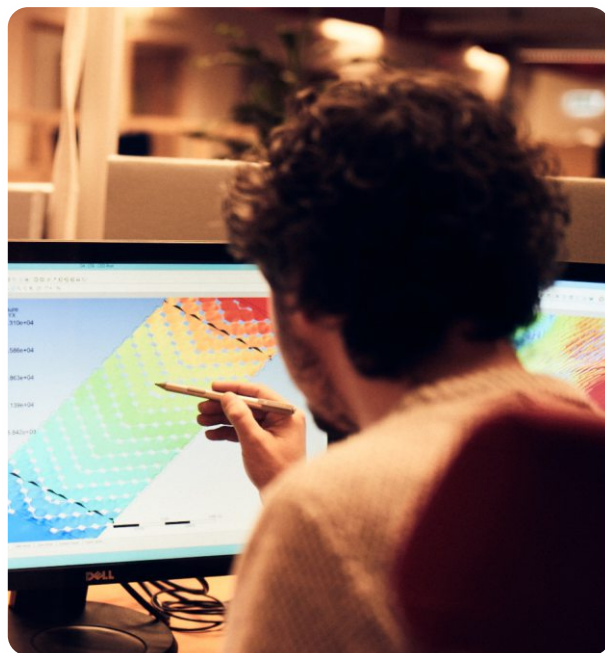

## Research with an open mind.

Engineers at SWEP worked closely with industry specialists and academics to set new standards in compactness and performance.



**Size of the problem**

Ambient air (temperature 20°C, relative humidity 60%) contains 10.4 g/m<sup>3</sup> moisture. To supply a compressor, intake 100 m<sup>3</sup>/h, with suitable air requires the removal of 1040 g/h of moisture.

# Smarter solution with integrated separation

In SWEP's ADWIS solution, the separator is sandwiched between two heat exchangers in a simple-looking yet highly efficient unit. In fact, simplicity is the key: separated water drains from the intuitively obvious place, the unit's lowest point, while connections and mountings are completely rationalized and you can use standardized insulation packages. And of course, simplicity means you save money on installation, running and maintenance.

## The smallest units available

Not only is the footprint small, thanks to highly efficient plate design, but the crucial height dimensions are also the smallest on the market. The ADWIS 5 envelope has a height of only 189 mm, while the ADWIS 12 envelope is only 289 mm, making it easy to design ADWIS into almost any system.



ADWIS - a simple concept realized with rational engineering.

## Rational solution

The engineering that goes into ADWIS is as rational as the concept is simple. For example, all connections for the refrigerant cycle are on one side, and all air connections on the other. There is no need for piping to an external separator, and you can save further costs and space by fitting the unit very closely to the system frame. ADWIS is also designed as a serial product, with each envelope having a wide capacity range.

## Constructed for strength

Components are stainless steel, for strength and resistance to corrosion, with copper-brazed exchanger plates. Both envelopes are rated to 16 bar on both the air and refrigerant sides. Furthermore, the high-capacity ADWIS 120-400 products have a maximum working pressure of 31 bar on the refrigerant side. SWEP's own cycle and thermal fatigue tests have confirmed the strength of the units. ADWIS will also safely satisfy short-term demands up to 30% higher than nominal capacity.

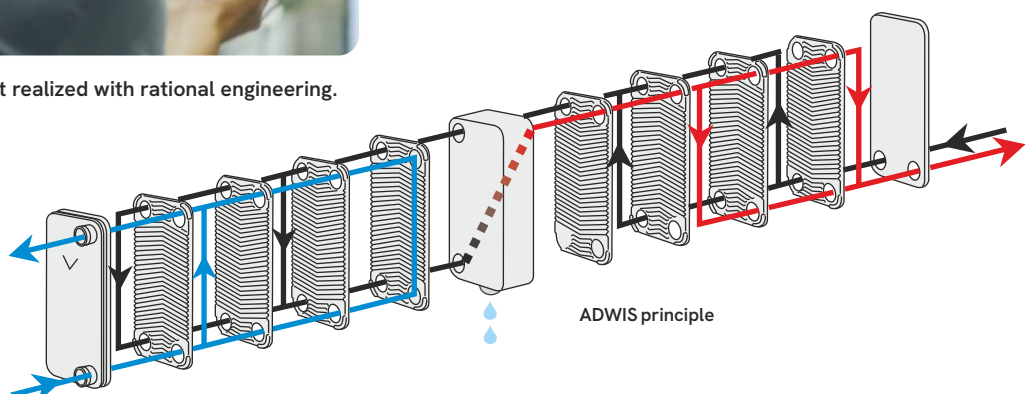

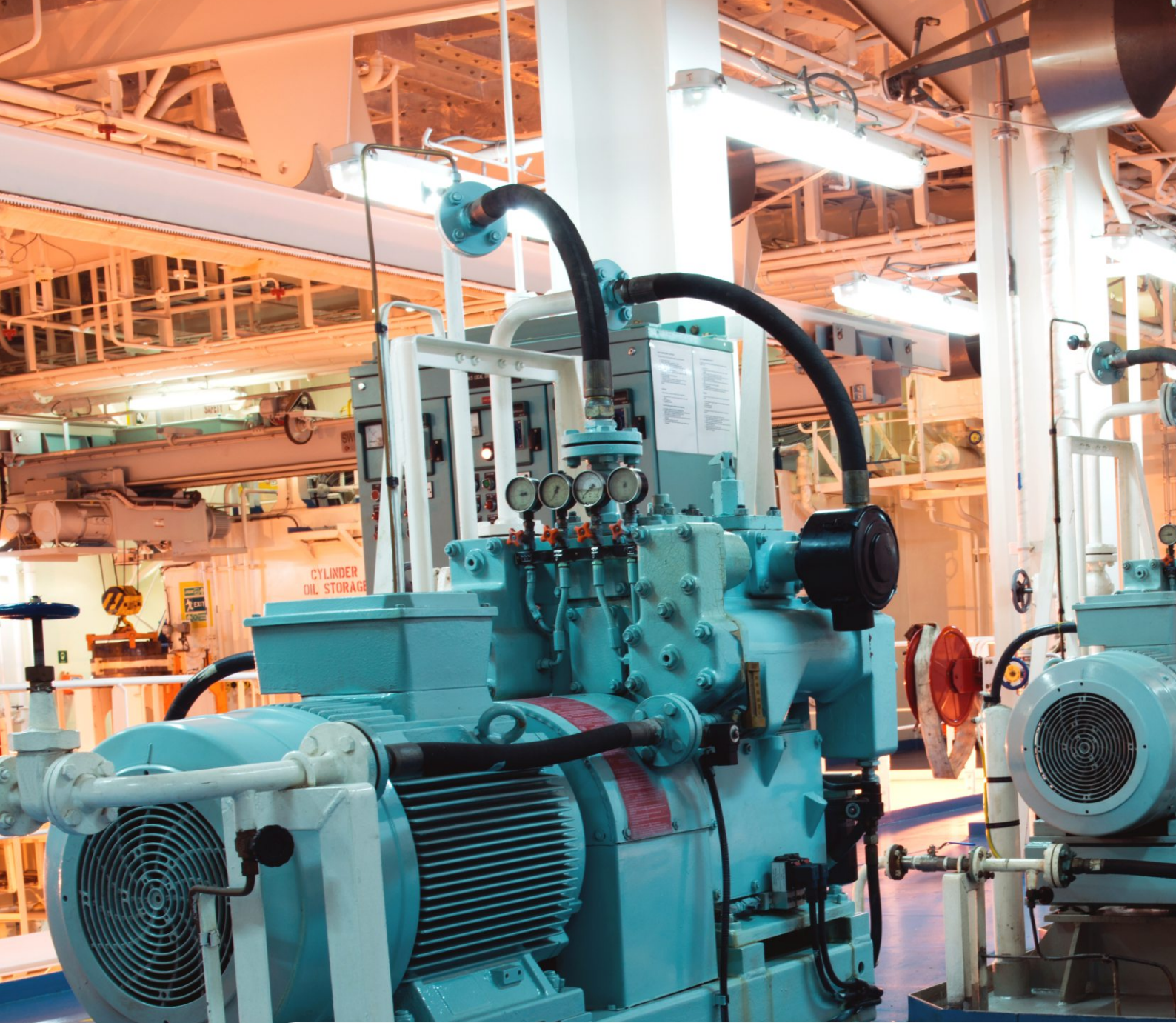

SWEP A5AS

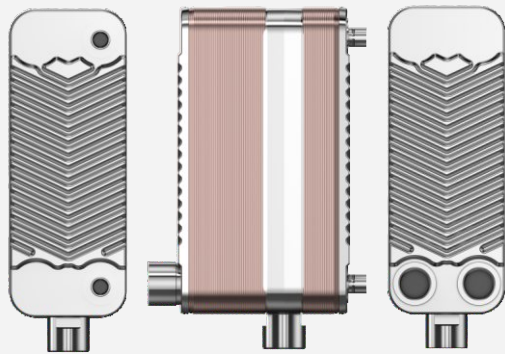

SWEP A12

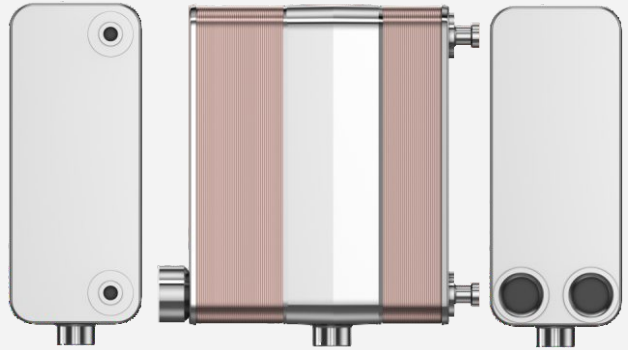

**Breakthrough compactness and simplicity.**

The new ADWIS has an elegant modular sandwich design with minimal piping, and covers the entire 35-400 Nm<sup>3</sup>/h capacity range with 11 models in just two envelopes.

# The breakthrough is available

The new ADWIS gives you complete, safe coverage of the 35-400 Nm<sup>3</sup>/h capacity range with 11 models in just two envelopes. It is a simple, rational and economical solution. Its dimensions - particularly its height - are the most helpful on the market. And it offers the great performance you expect from a SWEP product, of course. But perhaps best of all, ADWIS is available now for high-volume applications as well as individual solutions.



ADWIS is available now as a complete package, tested and with third-party approvals, from SWEP's network of international distribution centers. SWEP's smart logistics solutions give you rapid order processing, accurate information on progress and assured delivery.

## **Full coverage with just two envelopes**

The ADWIS family of 11 models spans a wide capacity range, yet there are only two basic envelopes, ADWIS 5 and ADWIS 12. This helps simplify your inventory and is also economical, because you save time on installation and maintenance and have the economic advantages of serial production.

## **Third-party approval obtained**

The quality of SWEP's products in general is assured by the company's ISO 9001 certification. In addition to SWEP's own rigorous testing (including cycle and thermal fatigue tests) and quality control, ADWIS has also undergone third-party testing. PED approval has already been obtained, and other approvals are pending or available on request.

## **Smart logistics solutions**

### **save you time and trouble**

When you have decided the capacities and quantities you need, SWEP's smart logistics solutions will give you assured delivery from our network of international distribution centers. Placing an order is easy, thanks to our eBusiness solutions, which also enable you to monitor the progress of your order online. For further information, please contact your local SWEP representative.

## SWEP A5AS

Range	Volume in Nm <sup>3</sup> /h*	SCFM
ADWIS 35	15 - 35	- 20
ADWIS 50	35 - 50	20 - 30
ADWIS 60	50 - 60	30 - 35
ADWIS 80	60 - 80	35 - 50
ADWIS 100	80 - 100	50 - 60

\* Design data: 8 bar (abs),  $t_{dew} = 3^{\circ}\text{C}$ ,  $dp = 20 \text{ kPa}$   $t_{in-out} = 8-10 \text{ K}$   
 116 psi (abs),  $t_{dew} = 37,4^{\circ}\text{F}$ ,  $dp = 2,9 \text{ psi}$   $t_{in-out} = 14^{\circ}-18^{\circ}\text{F}$

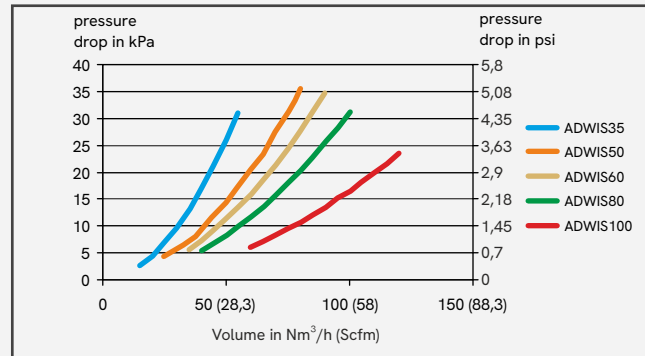

## SWEP A12

Range	Volume in Nm <sup>3</sup> /h	SCFM
ADWIS 150	100 - 150	- 95
ADWIS 200	150 - 200	95 - 125
ADWIS 250	200 - 250	125 - 155
ADWIS 300	250 - 300	155 - 185
ADWIS 350	300 - 350	185 - 215
ADWIS 400	400 -	215 -

\* Design data: 8 bar (abs),  $t_{dew} = 3^{\circ}\text{C}$ ,  $dp = 20 \text{ kPa}$   $t_{in-out} = 8-10 \text{ K}$   
 116 psi (abs),  $t_{dew} = 37,4^{\circ}\text{F}$ ,  $dp = 2,9 \text{ psi}$   $t_{in-out} = 14^{\circ}-18^{\circ}\text{F}$

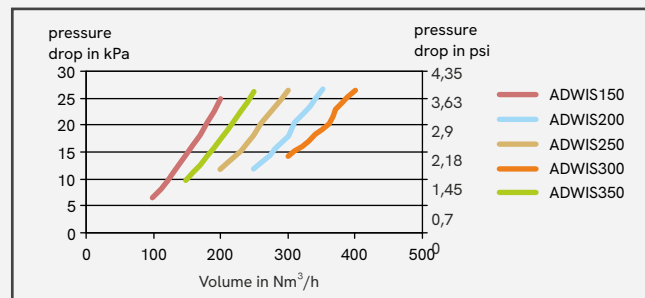

The breakthrough dimensions speak for themselves. The 11 ADWIS models are derived from just two basic envelopes, giving you a rational product with lower installation and maintenance costs.



The ingenious modular design makes ADWIS suitable for economical serial manufacturing, bringing down your costs and assuring availability.

SWEP ensures efficient heat transfer where less means more. Since 1983, millions of our innovative brazed plate heat exchangers have been integrated into HVACR and industrial applications worldwide, enhancing the quality of life for billions of people. Our expertise in sustainable energy use has grown SWEP into a global company with more than 1,100 employees, five production sites, and a presence in 50 countries. As part of Dover Corporation, we help redefine what is possible within the Climate & Sustainability Technologies segment.

Make a difference. Visit [swepgroup.com](http://swepgroup.com).

[swepgroup.com](http://swepgroup.com)

