

客户(CUSTOMER): 通用

---

# 压缩机规格书

COMPRESSOR SPECIFICATION

型号(MODEL): ATz-AN088ACBA-B

## 需方确认 (CUSTOMER CONFIRMATION)

审核 (CHECKED BY): \_\_\_\_\_

批准(APPROVED BY): \_\_\_\_\_

空调器型号(AIR CONDITIONER MODEL): \_\_\_\_\_

## 供方确认 (SUPPLIER CONFIRMATION)

编制 (DESIGNED BY): \_\_\_\_\_ 李雄辉

审核 (CHECKED BY): \_\_\_\_\_ 徐玉格

标准化(STANDARDIZED BY): \_\_\_\_\_ 余文彬

审定 (PROVED BY): \_\_\_\_\_ 陈迪松

批准(APPROVED BY): \_\_\_\_\_ /

珠海凌达压缩机有限公司

ZHUHAI LANDA COMPRESSOR CO., LTD.

# 目录

## Contents

一、适用范围 <b>Application Scope</b> .....	<b>1</b>
二、规格特性 <b>Specifications &amp; Characteristics</b> .....	<b>1-8</b>
1、压缩机规格 Compressor data	
2、电机规格 Motor data	
3、电器部品 Electrical component	
4、性能 Performance	
5、使用条件 Application condition	
6、许可运行压力范围 Range of operating pressures	
7、水分和杂质含量要求 Moisture and Impurities	
8、压缩机开停机控制 Start-stop limitation	
9、压缩机转速变化率 Rate of rotational speed change	
三、注意事项 <b>Cautions</b> .....	<b>9-11</b>
四、附件及图纸 <b>Accessories &amp; Drawings</b> .....	<b>12-21</b>
1、压缩机附件 Accessories	
2、压缩机相关图纸 Drawings	

## 适用范围

➤ 适用范围 APPLICATION SCOPE

此规格适用于 ATz-AN088ACBA-B 旋转式压缩机

This specification is applied to ATz-AN088ACBA-B rotary compressor.

用途 Application	房间空调器 Room air-conditioner
制冷剂 Refrigerant	R410A
最大制冷剂充注量 Refrigerant charge limit	1000g MAX
控制器输入端额定电压/频率/相数 Inverter Input Rated Voltage/ Frequency/Phase	220V/50HZ/1 PHASE
压缩机运行机械频率 Compressor Operation Frequency	15~120Hz

## 规格特性

1. 压缩机规格 COMPRESSOR DATA

压缩机类型 Compressor type	全封闭型电动机压缩机 Hermetic motor compressor
泵体类型 Pump type	旋转式 Rotary
气缸数 The number of cylinders	单缸 single cylinder
气缸名义工作容积 Cylinder nominal volume	8.8 cm <sup>3</sup>
冷冻油牌号 Brand of refrigerant oil	RB68EP or equivalent
冷冻油充注量 Refrigerant oil charge	260 ml
重量(含冷冻油) Weight(Refrigerant oil included)	7.0 kg
吸气管内径 Suction pipe I.D.	Φ9.7±0.05 mm
排气管内径 Discharge pipe I.D.	Φ8.2±0.06 mm

2. 电机规格 MOTOR DATA

电机类型 Motor type	永磁同步电机 Permanent Magnet Synchronous Motor		
启动类型 Starting type	直流变频控制器 DC variable frequency inverter		
极数 Pole	6 poles		
额定输出功率(60Hz) Rated output power(60Hz)	680	W	
额定转速(60Hz) Rated speed(60Hz)	3600	rpm	
磁通 (线间) Magnetic flux (Line)	450	mWb	
电压常数 (线间) Voltage constant (Line)	50.3	Vrms/Krpm	
转矩常数 Torque constant	0.78	N•m/Arms	
转动惯量 Moment of inertia	232	Kg.mm <sup>2</sup>	
绕组电阻 (25℃) (线间) Winding resistance (line-to-line)	2.62±7%Ω		
绝缘等级 Insulation class	E		
电感量测定结果 (测定频率: <u>50</u> Hz) The result of inductance test(50Hz)	电流 Current (A)	电感 (mH) Inductance (mH)	
		Ld (相间)	Lq (相间)
	5.0	10.64	14.26
退磁电流 (电机每相) Demagnetizing current (Motor Phase)	环境温度 Ambient temperature	120℃	
	保护推荐电流 (峰值) Recommended protection current(peak value)	23A Max	

3. 电器部品 ELECTRICAL COMPONENT

名称 Name	规格 Specification	动作温度℃ Operating temperature	复位温度℃ Reset temperature
过载保护器 Overload protector	无	无	无
	无		
	无		

4. 性能（用专用控制器测试）PERFORMANCE（In special inverter test）

➤ 额定性能 RATED PERFORMANCE

性能参数 Performance parameter	额定值(60Hz)	
转速 Speeds of rotation	3600	r/min
制冷量 Cooling Capacity	3175±5%	W
控制器端输入功率 Inverter Input power	749±5%	W
能效比 C.O.P.	4.24	W/W
输入控制器电流 Inverter input current	3.7±10%	A
噪声（A 计权声压级噪音值） Noise(A weighted sound power)	≤72	dB(A)
振动（压缩机本体切向加速度） Vibration(Compressor tangential acceleration)	≤15	m/s <sup>2</sup>

➤ 一般性能 GENERAL PERFORMANCE

运行电压范围（控制器内部 PWM） Range of Run voltage（Inside Inverter PWM）	DC 260-350	V
压缩机开停次数 Compressor cycle	≥10000	次
气密性试验压力 Leak test pressure	4.3~4.5	MPa

➤ 安全性能 SAFETY PERFORMANCE

电气强度 Electrical strength	1500V/min 或 1800V/s, 泄漏电流不大于 5mA 1500V/min or 1800V/s, leak current less than 5mA
壳体耐压试验压力 Shell test pressure	> 15.86 MPa
绝缘电阻 Insulation resistance	> 500 MΩ
接地电阻 Grounding resistance	≤ 0.1 Ω

➤ 制冷量测试工况 COOLING CAPACITY TESTING CONDITION

测试电源（输入控制器） Testing power supply (Input inverter)	220V/50Hz
蒸发温度 Evaporating Temp.	10°C
冷凝温度 Condensing Temp.	46°C
液体温度 Liquid Temp.	41°C
吸气温度 Suction Temp.	18°C
环境温度 Ambient Temp.	35.0°C
测试风速 Testing air flow	≤ 2m/s

5. 使用条件 APPLICATION CONDITION

序号 No	项目 Item	标准条件 Standard Load Condition	过负荷条件（不连续使用） Overload Condition(Should Not Be Continuous)	备注 Note	
1	制冷剂 Refrigerant	制冷剂必须使用 R410A（HFC32/HFC125） 各项纯度应在 99.8%以上			
2	频率 Frequency	15Hz~120Hz			
3	蒸发温度范围 Evaporating Temperature Limit	-15℃~+15℃ (0.38MPa~1.15MPa)	下限：在制热启动时或冷暖切换 时允许短时间（2-5min）过载， 蒸发温度下限为-25℃（0.23MPa） 上限：在过负荷条件下蒸发温度 上限为 20℃（1.35MPa）	蒸发器入口、 出口平均温度	
4	冷凝温度范围 Condensing Temperature Limit	27℃~65℃ (1.65MPa~4.15MPa)			冷凝器入口、 出口平均温度
5	压缩比 Compression Ratio	2~6	允许短时间（2~5min）过载，压 比控制在 7.5 以下		
6	压差 Pressure Difference Between Suction And Discharge	正常运行时需保证吸排气压力差在 0.4MPa 以上			
7	异常压力升高 Abnormal Rise In Pressure	冷凝器阻塞或风扇故障时压力异常升高的极限值为 4.9MPa			
8	电机绕组温度 Motor winding Temperature	115℃以下	120℃以下		
9	排气温度 Discharge Gas Temperature	110℃以下	115℃以下	距离压缩机出 口 100mm 的 排气管处测量	
10	吸气温度 Suction Gas Temperature	35℃以下，同时保证吸气温度比蒸发温度高 1℃以上			距压缩机入口 50mm 处吸 气管处温度
11	壳体底部温度 Compressor Case Bottom Temperature	高于排气压力对应的饱和温度 5℃以上			距离下盖 30mm 处测量

6. 许可运行压力范围 Permitted range of operating pressure

压缩机实际运行压力范围与控制器控制策略有关。

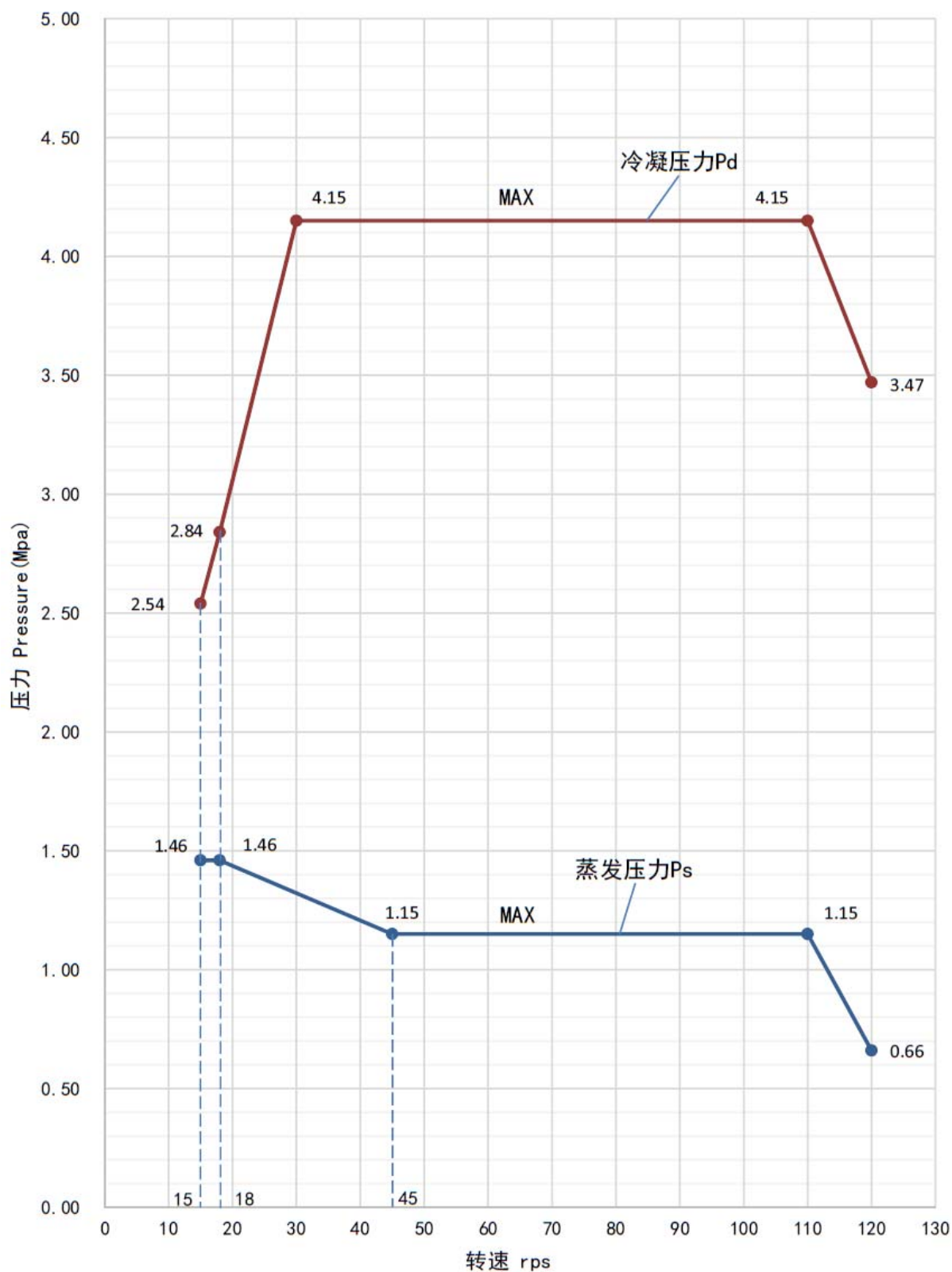

7. 水分和杂质含量要求 Moisture and impurity

序号 No	项目 Item	使用界限 Operational Limit
1	压缩机残余水分量 Residual Moisture	≤100mg
2	压缩机残余杂质质量 Residual Impurities	≤100mg
3	残余氯含量 Residual Chlorine	30mg MAX
4	制冷系统最大残余含水量 Residual Moisture In The Syetem	0.2ml MAX
5	制冷系统最大残余杂质含量 Residual Impurities In The Syetem	0.08 g / m <sup>2</sup> MAX
6	制冷系统最大残余空气量 Residual non-condensable Gas In The System	30 ml MAX
7	充入系统中冷冻油含水量 Moisture of refrigerant oil charged in the System	100ppm MAX

8. 压缩机开停机控制 Start-stop limitation

项目 Item	标准条件 Standard Load Condition	过负荷条件 Overload Condition
平衡压力 Pressure	高低压平衡时，整机才能启动。 启动时平衡压力≤1.65MPa	启动时平衡压力≤1.75MPa
启动时压差 Starting Pressure	压缩机启动时高低压压力差（排气压力-吸气压力）≤0.05MPa	
启动温度 Starting Temperature	开机时的环境温度或压缩机内部温度需大于冷媒与冷冻油二层分离温度	
运行时间 Operating time	≥3min	≥5min
停机时间 Stopping time	从断开至高低压平衡的时间，以便再次启动。 一般情况下≥3min	一般情况下≥5min
开-停周期 On/Off Cycle	1小时内开停次数≤10次	

9. 压缩机转速变化率 Rate of rotational speed change

阶段 Phase	频率段 Frequency	升频速度 Acceleration Ratio	降频速度 Deceleration Ratio	频率改变幅度 Range of Frequency	稳定时间 Time Maintained
启动阶段 Start Up	异步启动到同步驱动的过程需控制在 20s 以内 30HZ 以下； 同步驱动阶段：参照一般运转条件。				
一般运转 General Driving	<30Hz	≤2Hz/s	≤1Hz/s	一次升频幅度：≤30Hz 一次降频幅度：≤10Hz	≥10s
	30~80Hz	≤2Hz/s	≤2Hz/s	≤30HZ	≥10s
	>80Hz	≤1Hz/s	≤2Hz/s	一次升频幅度：≤10Hz 一次降频幅度：≤30Hz	≥10s
注意事项 Notice Item	压缩机在连续升降频过程中，需保证压缩机油面高度满足要求； 压缩机启动时，必须在 40Hz 到 65Hz 频率范围内至少运行 1 分钟以上，以确保供油充足，低于该频率段时须向规格书提供方确认。				

## 注意事项

### ➤ 压缩机使用注意事项 PRECAUTIONS ON OPERATION

#### 1. 严格遵守规格书 Strictly observe the specification

本压缩机应在本规格书规定的范围内使用，不能超出压缩机的使用范围，如遇特殊情况，需向研发部门确认。附件也应使用指定的零部件。

The compressor should be used in specifications written in this “compressor specification” and not be used in specifications outside of it. Moreover, accessories should be specified parts used in specified way; service must use specified parts too.

#### 2. 频率范围 Frequency

运行频率必须在 15~120Hz 的范围之内。

The running frequency shall be within 15~120Hz.

#### 3. 电源电压 Source voltage

为了防止磁铁退磁，在设计变频系统时必须保证转子内的永久磁铁在任何情况下都不会被退磁；必须使用专用的变频器，一定不能使用感应电机所用的变频器或（直接）使用商用电源。

In order to prevent the permanent magnet to be demagnetised, the frequency conversion system must ensure the permanent magnet not be demagnetised in any situation; use the special inverter, do not use a induction motor inverter, and do not use commercial power supply.

#### 4. 起动-停止要求 Start-stop limitation

压缩机起动运行前应确保接线正确，绝对禁止压缩机反向运转和在空气中运行；载波频率必须不能引起压缩机共振；

Make sure that wiring is correct before starting the compressor, it is forbidden to run compressor in reverse direction and in the air; and carrier wave frequency must not arise the resonance;

#### 5. 压缩机回油回液限制 Liquid refrigerant and oil return limitation

1) 压缩机充入制冷剂后，必须运转 20s 以上，以保证适当的润滑。

The compressor should be operated for more than 20 seconds after charging refrigerant into the system for proper lubrication results.

2) 在压缩机稳定运行时，系统内温度不应低于-35℃，以防止油中蜡的成分沉淀。

Temperature within systems during stable compressor operation should not be less than -35℃ to prevent the wax in the oil from precipitation.

3) 压缩机已装入了规定的适量冷冻油，使用时不得增加或减少。

Do not reduce or increase the refrigerant oil during application as the compressor has been charged with specified amount of oil.

4) 当压缩机内部的制冷剂和冷冻油处于二层分离时, 压缩机不能启动。

Compressor must not be started under a dual-layer separate status.

5) 为保证制冷系统的油流回压缩机, 在设计管路时气体的最小速度, 水平管内为 4m/s, 垂直管内为 7m/s。

To ensure the oil inside the refrigerating system returns to compressor, when designing the piping, the minimum gas velocity is 4m/s for horizontal pipe, and is 7m/s for vertical pipe.

6) 为了防止制冷剂液体积蓄在压缩机中, 应保证压缩机壳体底部的温度大于冷凝温度 5℃以上。

To prevent the liquid refrigerant accumulating in the compressor, ensure that the temperature at bottom of compressor case is higher than the condensing temperature.

#### 6. 压缩机倾斜 Allowable Incline

压缩机在倾斜角 5°范围内可以正常运转。

The compressor shall operate properly with tilting angle below 5°.

#### 7. 压缩机存放 Preservation

1) 不得有水溅入压缩机内。

The compressor should not be splashed with water inside.

2) 压缩机不得在空气中持续打开 15 分钟以上。

The compressor should not be left open in the atmosphere for more than 15 minutes.

3) 禁止压缩机横放、倒置、跌落, 不要把压缩机放置在露天, 必须将压缩机存放在-10℃~+65℃的室内。

Do not put the compressor horizontally or put it upside down. Do not let the compressor falls off. Do not put the compressor in the open air, put the compressor inside the room where the temperatures inside range between -10℃~+65℃.

#### 8. 工艺限制 Process limitation

1) 压缩机内部已封入了干燥氮气, 使用时应先拔掉高压侧(排气管)的橡胶塞, 否则冷冻油会喷出压缩机。

Compressor is charged with dry nitrogen, remove high pressure side (discharge tube side) rubber plug first before application, otherwise refrigerant oil will gush from the compressor.

2) 只使用规定的制冷剂 R410A, 制冷剂应从制冷系统冷凝器的尾端注入, 而不能直接注入压缩机, 当制冷剂量超出规定值时, 应同我公司联系。

Only R410A is permitted. Refrigerant should be charged from the end of the condenser of the refrigerating systems. Never charge refrigerant to the compressor directly. When the charge amount exceeds designated value, contact us.

3) 压缩机与配管, 配管与配管之间的焊接应注意决不能让焊药、灰尘等杂质进入制冷系统。

Take care that the foreign matters like solder, dust, etc will not get into the refrigerating system from soldering/welding joints between compressor and piping, as well as between piping.

4) 在装配系统时应保证系统洁净，为防止毛细管等堵住，必须在制冷回路中装上过滤器。

Keep the system clean during assembly, the filter shall be assembled into the refrigerating loop to prevent block up of capillary tube etc.

9. 其它 Other Conditions

1) 压缩机不得自身抽真空及空运转，系统抽真空应保证抽到绝对压力为 133Pa 以下。

The compressor should not be operated to form a vacuum or to absorb air; the evacuation of the system shall ensure that absolute pressure is below 133Pa..

2) 当压缩机处于真空状态下，不应向密封接线柱上加电脉冲。

The electric pulse should not be applied to the hermetic terminals when the compressor is under vacuum.

附件及图纸

1. 压缩机附件 ACCESSORIES

名称 Name	数量 Quantity	说明 Description
接线柱护盖 Terminal cover	1	已配备 Loaded
螺母 Nut	1	已配备 Loaded
减振垫圈 Grommet	3	已配备 Loaded
绝缘垫 Gasket	1	已配备 Loaded
过载保护器 Overload protector	无	无

2. 压缩机相关图纸 DRAWINGS

名称 Name	代号 Symbol
外形尺寸图 Outside dimension	ATz-DW-01
性能曲线图 Performance diagram	ATz-DW-02
电气安装及底脚安装图 Wiring & mounting plate installation	ATz-DW-03
铭牌 Name plate	ATz-DW-04
接线柱护盖 Terminal cover	ZE7.852.014
绝缘垫 Gasket	ZE8.683.014
减振垫圈 Grommet	ZE8.639.687
过载保护器 Overload protector	无

外形尺寸图  
OUTSIDE DIMENSION

型号 (MODEL): ATz-AN088ACBA-B

ATz-DW-01

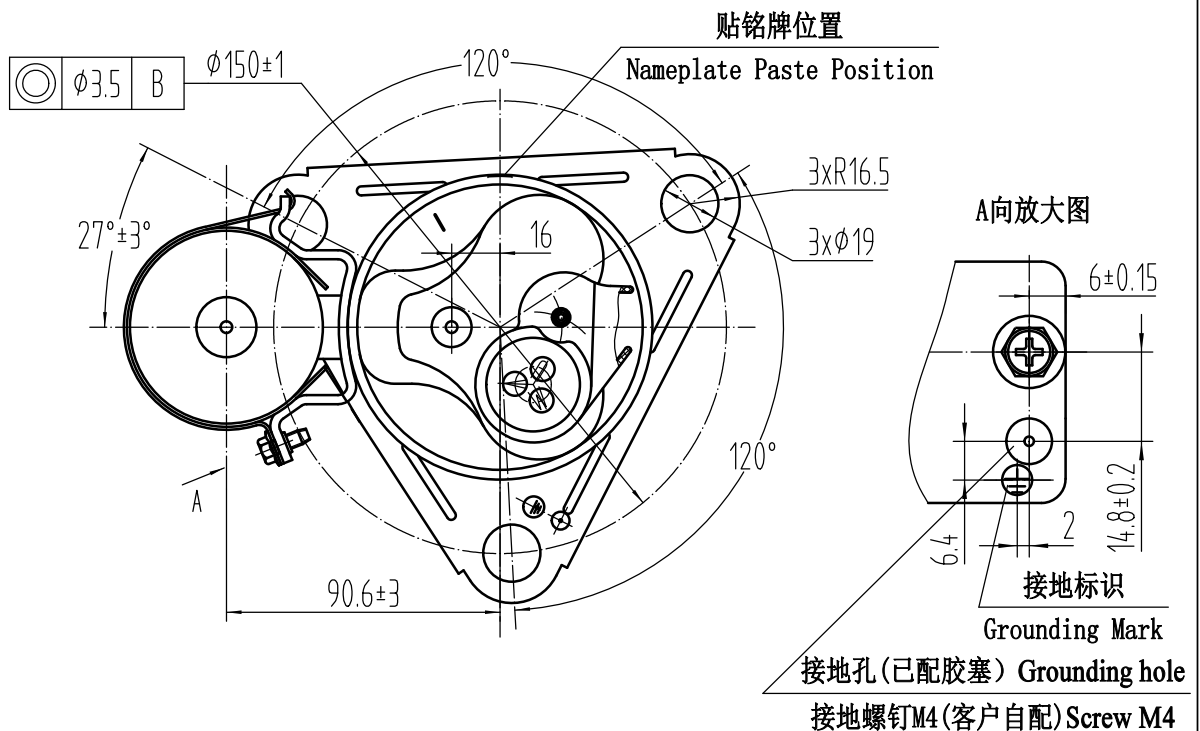
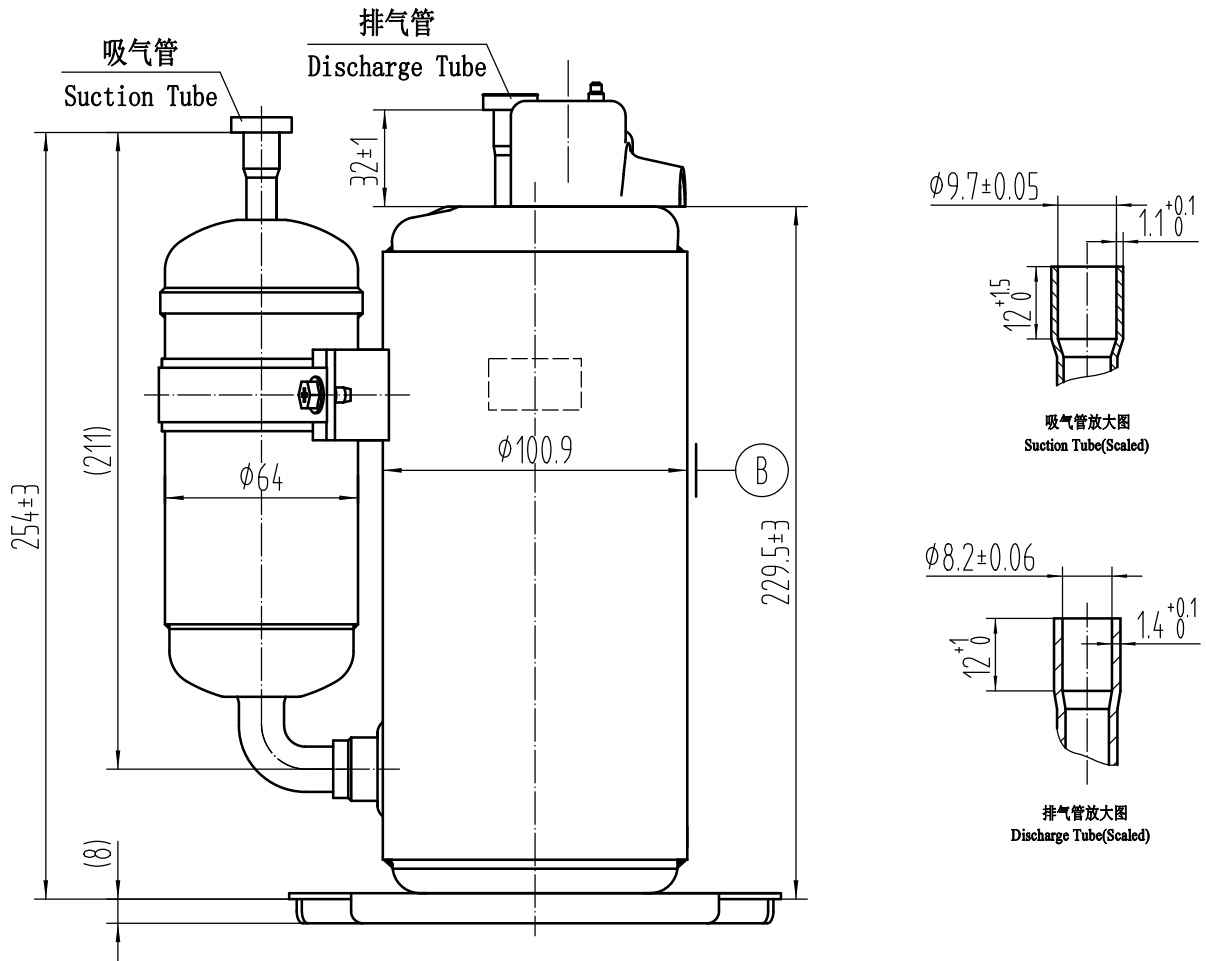

性能曲线图  
 PERFORMANCE DIAGRAM  
 型号(MODEL): ATz-AN088ACBA-B

PAGE: 14/21

ATz-DW-02

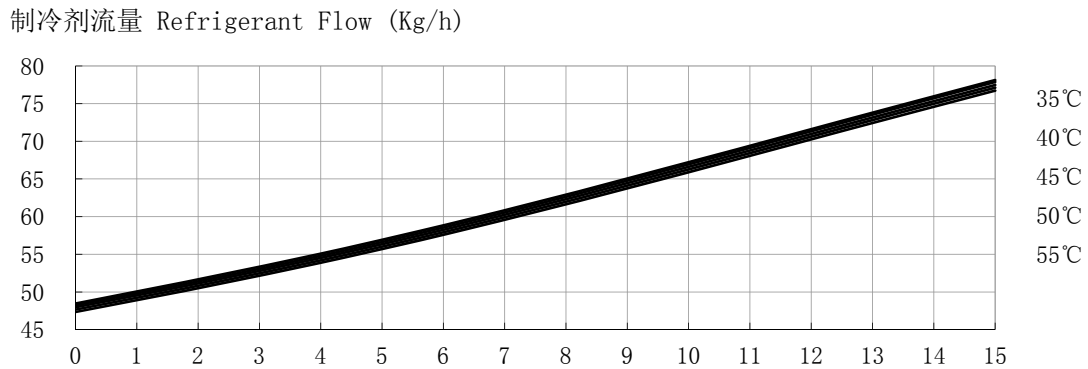
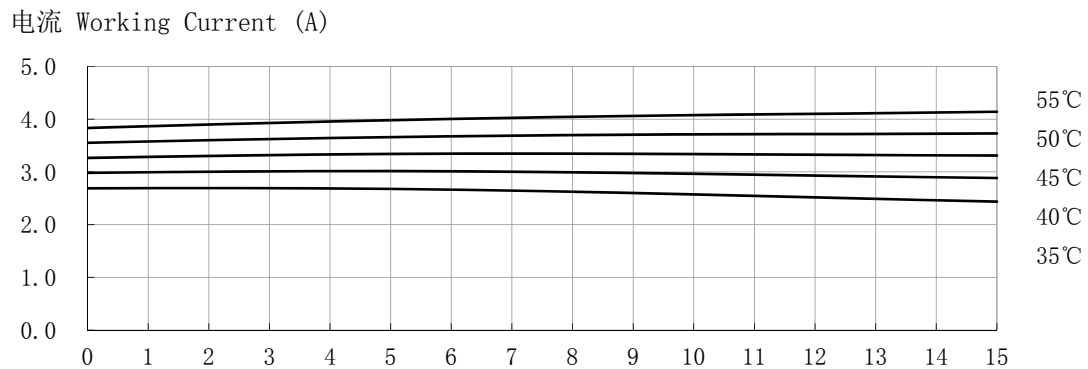
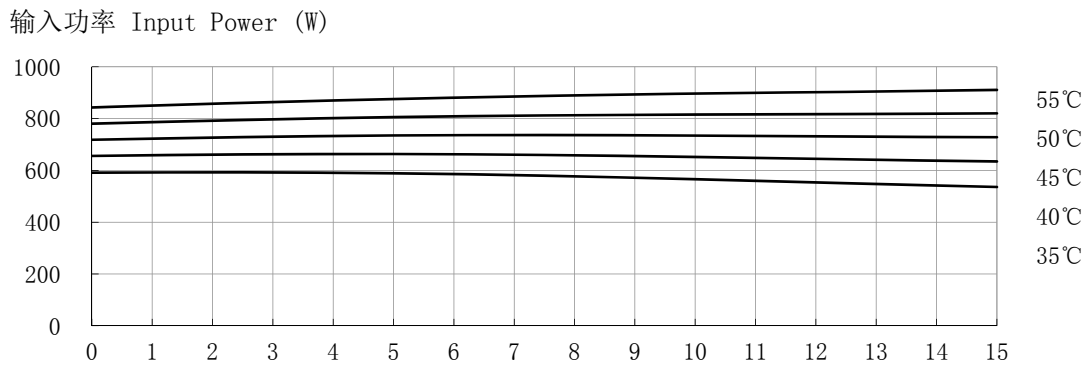
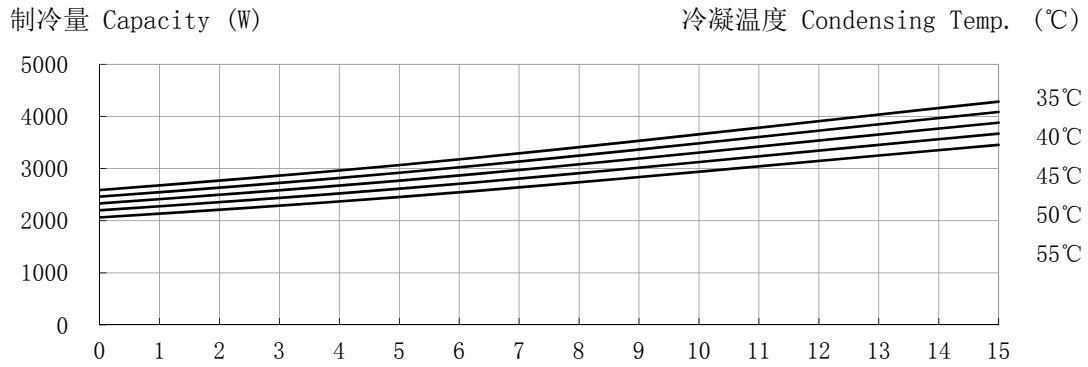

蒸发温度 Evaporating Temp. (°C)

**电路图 Wiring Diagram**

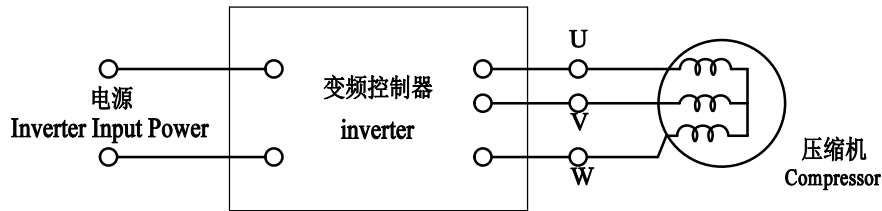

**接线安装图 Electric Connecting Drawing**

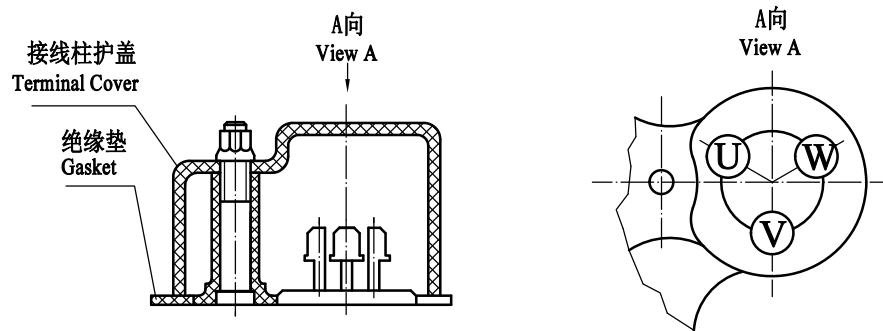

注：全金属法兰面螺母的拧紧力矩为1.0~1.5Nm  
 The tightening torque for the metallic flange nut is 1.0~1.5Nm

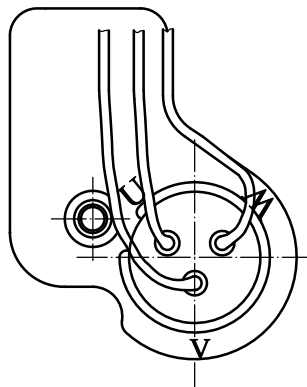

**支脚安装图 Mounting Plate Installing**

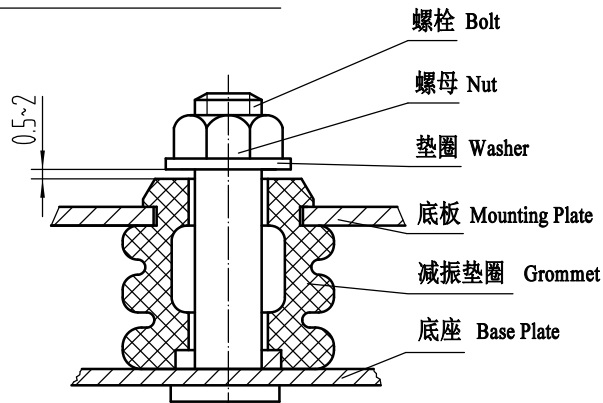

铭 牌

NAME PLATE

型号 (MODEL): ATz-AN088ACBA-B

PAGE: 16/21

ATz-DW-04



厂家代码

The code of manufacturer

质量跟踪编号

Quality tracking number

产品单元码

The code of product

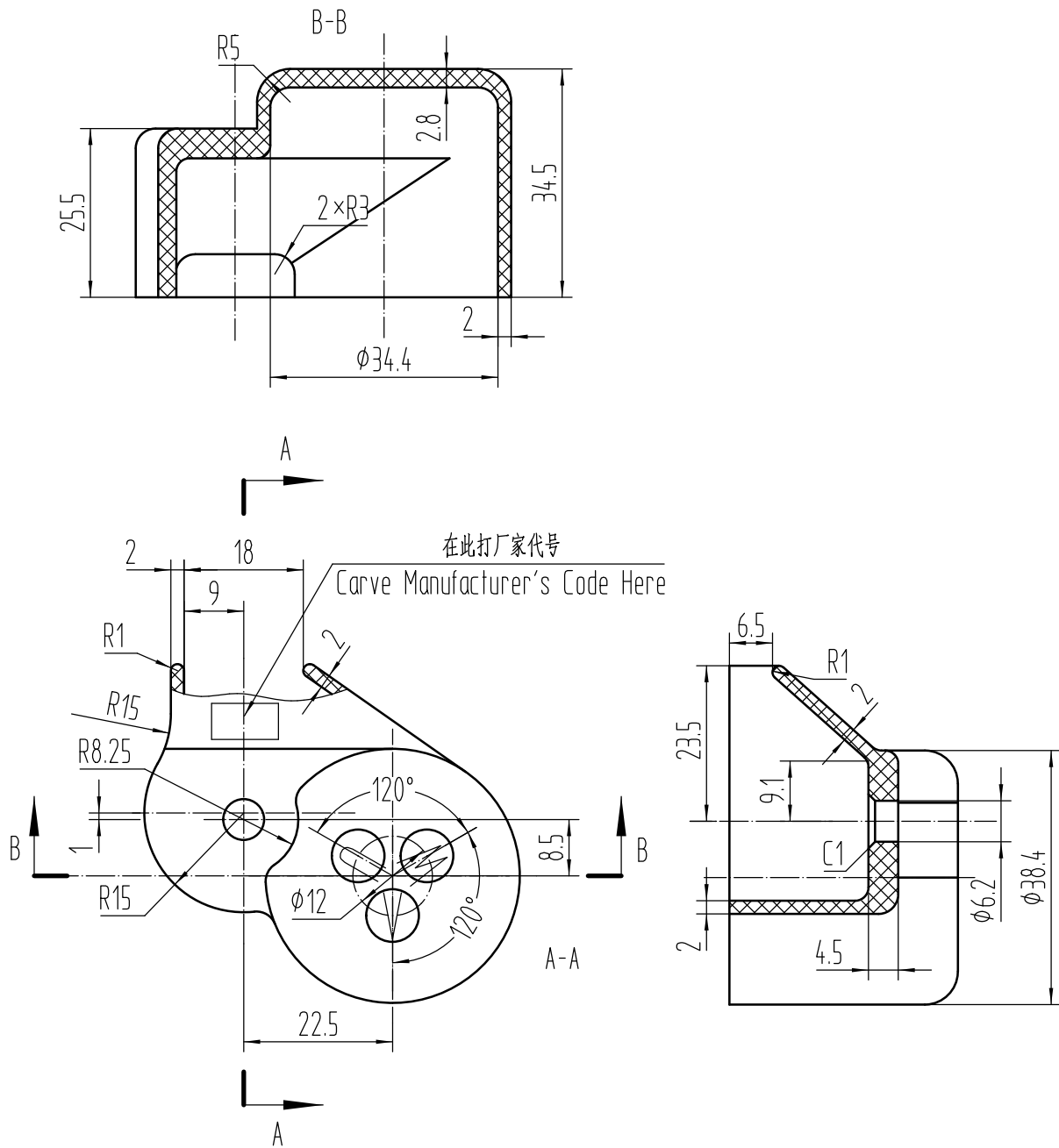

技术条件  
Specifications

- 1、零件表面应光滑、无毛刺；  
Part surfaces shall be smooth without burrs；
- 2、保护盖颜色为黑色；  
The cover is black；
- 3、零件材料为PET-FR330。  
The material of part is PET-FR330.

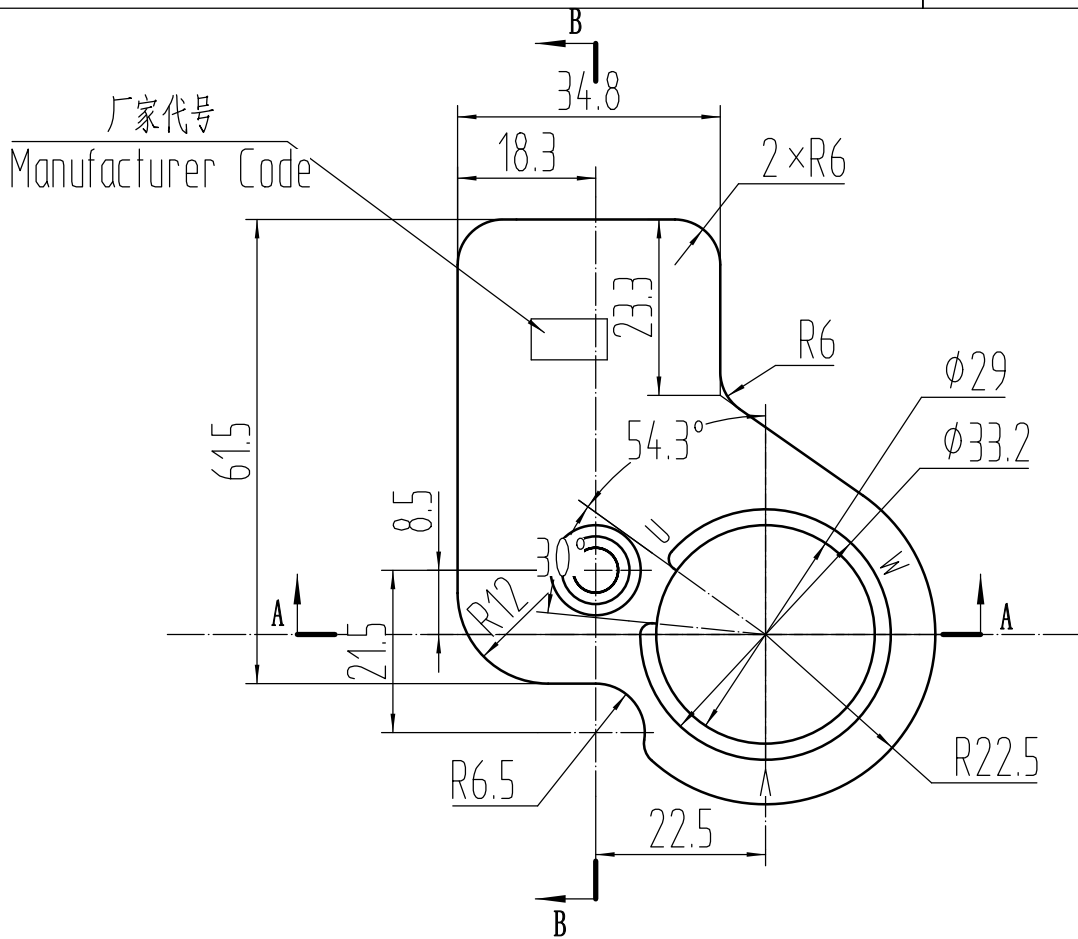

技术要求  
Specifications

- 1、零件颜色为黑色；  
The part is black;
- 2、零件所用材料：阻燃硅胶或者三元乙丙橡胶；  
The material of part is Flame Retardant Silica Gel or EPDM.
- 3、零件的硬度为Hs70° ±5° 。  
The hardness of part is Hs70°±5°.

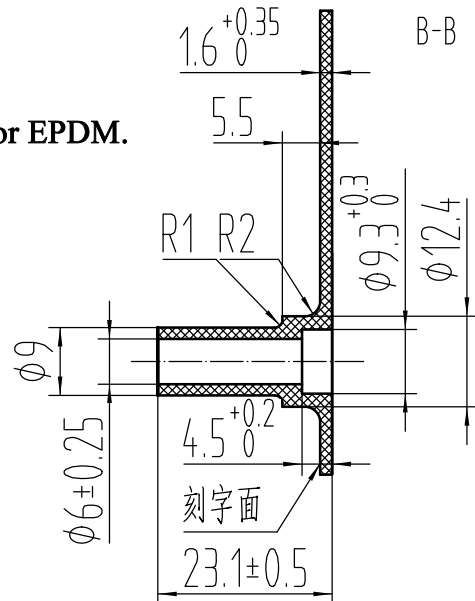



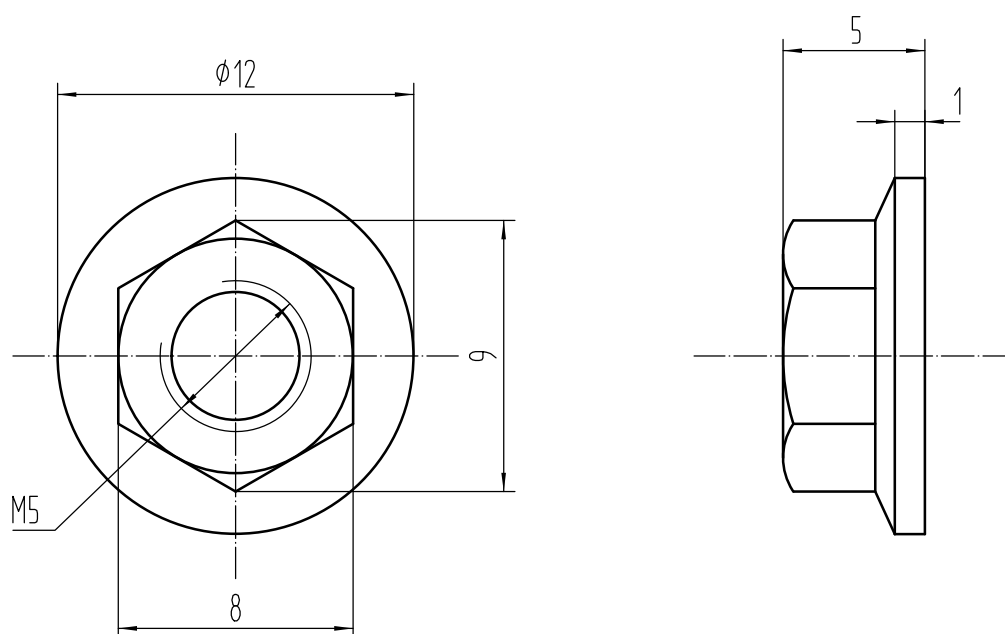

技术要求  
Specifications

1. 零件符合GB/T6177.1;  
The part must adapt to the GB/T6177.1;
2. 零件所用材料: 钢。  
The material of part is STEEL.

◇ 本规格书修订记录表:

标记	处数	更改文件号	签字	日期
A 版	/	首次发布	李雄辉	2018-4-18
B 版	2	LSBG00944123	李雄辉	2018-7-9
C 版	3	LSBG00951802	李雄辉	2018-8-11