

Input data

Refrigerant	R134a	
Reference temperature	Dew point temperature	
Calculation mode	Refrigeration / Air Cond.	
Operating mode	Subcritical	
Power supply	400/3/50	
Condensing temperature	°C	45
Condensing pressure	bar	11.6
Liquid subcooling	K	2
Liquid temperature	°C	43
Evaporating temperature	°C	-5
Evaporating pressure	bar	2.43
Suction gas temperature	°C	20
Evaporator superheating	K	5

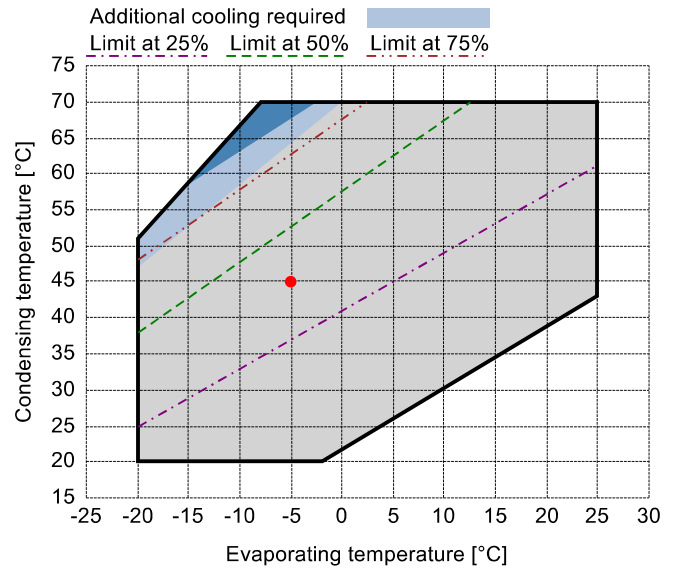

Output data

Compressor :	CXH02-80-230Y	
Number of compressors :	FSx1	
Refrigerating capacity	kW	98.075
Refrigerating capacity [*ref]	kW	93.791
Evaporator capacity	kW	86.955
Power input	W	36501
Condenser capacity, theor.	kW	134.576
Current	A	63.61
COP/EER	W/W	2.38
Mass flow	kg/h	2264
Operating frequency	Hz	50
Connection	-	PWS
Operating mode	-	100%
Discharge temperature	°C	92.92
Ratio (%)	%	100.0%
Note	-	
Oil flow	l/min	12.63
Heat Exchanged (oil Cooler)	kW	-
Oil Temp. at Oil Cooler Outlet	°C	-
Certified by	-	Frascold

Certified by:

- Frascold tentative data

Legend:

- *ref: At conditions according to EN12900
- Suction gas superheating = 10 K
- Liquid subcooling = 0 K

P&I Diagram:

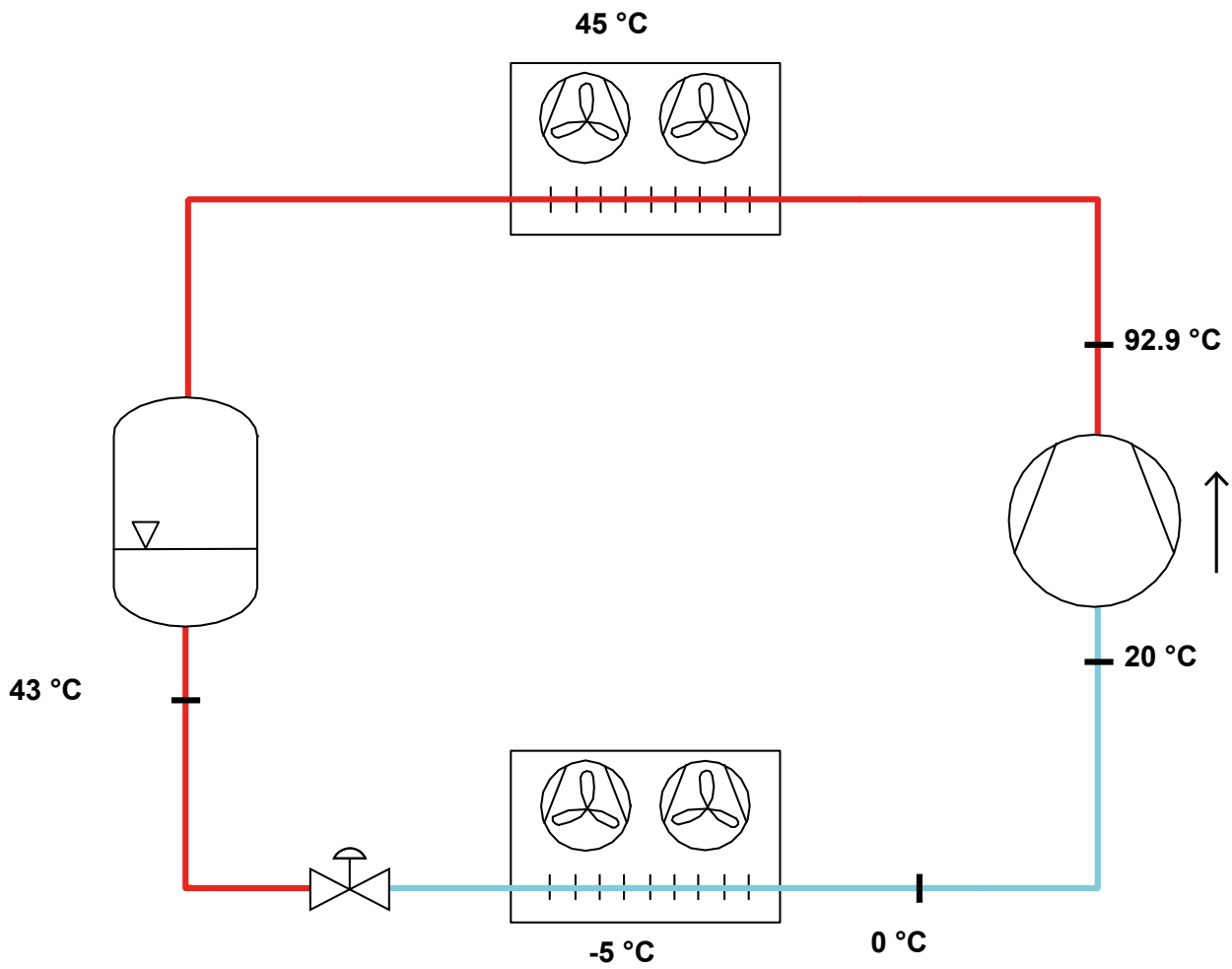

Oil separator:

Name		WK200
Number of separators		1

Results

Number of compressors, maximum		2
Utilization (Number of separators)	%	50
Refrigerant mass flow, maximum	kg/h	2370
Utilization (Refrigerant mass flow)	%	95.51
Oil flow, maximum	l/min	51.6
Utilization (Oil flow)	%	24.48

Selection parameters

Number of compressors		1
Mass flow, Compressors	kg/h	2264
Oil flow, Compressors	l/min	12.63

Operating conditions

Evaporating temperature	°C	-5
Suction gas temperature	°C	20
Condensing temperature	°C	45
Liquid temperature	°C	43

All data subject to change without notice

Model: CXH02-80-230Y

Refrigerant: R134a

Power supply: 400/3/50 PWS

Technical data:

Displacement	230 m³/h
Nominal compressor speed	2900 rpm
Motor voltage	400 V
Nominal operating frequency	50 Hz
Maximum allowed operating current (MRA)	145 A
Locked rotor current (LRA)	373 A
Locked rotor current (LRA), DOL	600 A
Net weight	550 kg
Lubricant	FRASCOLD POE170
Oil charge	11 l
Maximum static pressure LP	20.5 bar
Maximum operating pressure HP	30 bar

Sound level:

Sound power level 5/50°C R407C @50Hz	86.6 dB(A)
Sound pressure (*) - Distance: 1 m	78.6 dB(A)
Sound power level 5/50°C R134a @50Hz	85 dB(A)
Sound pressure (*) - Distance: 1 m	77 dB(A)

*half sphere model

Motor connections:

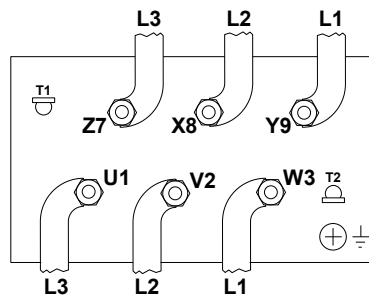

All data subject to change without notice

Model: CXH02-80-230Y

Refrigerant: R134a

Power supply: 400/3/50 PWS

Dimensions:

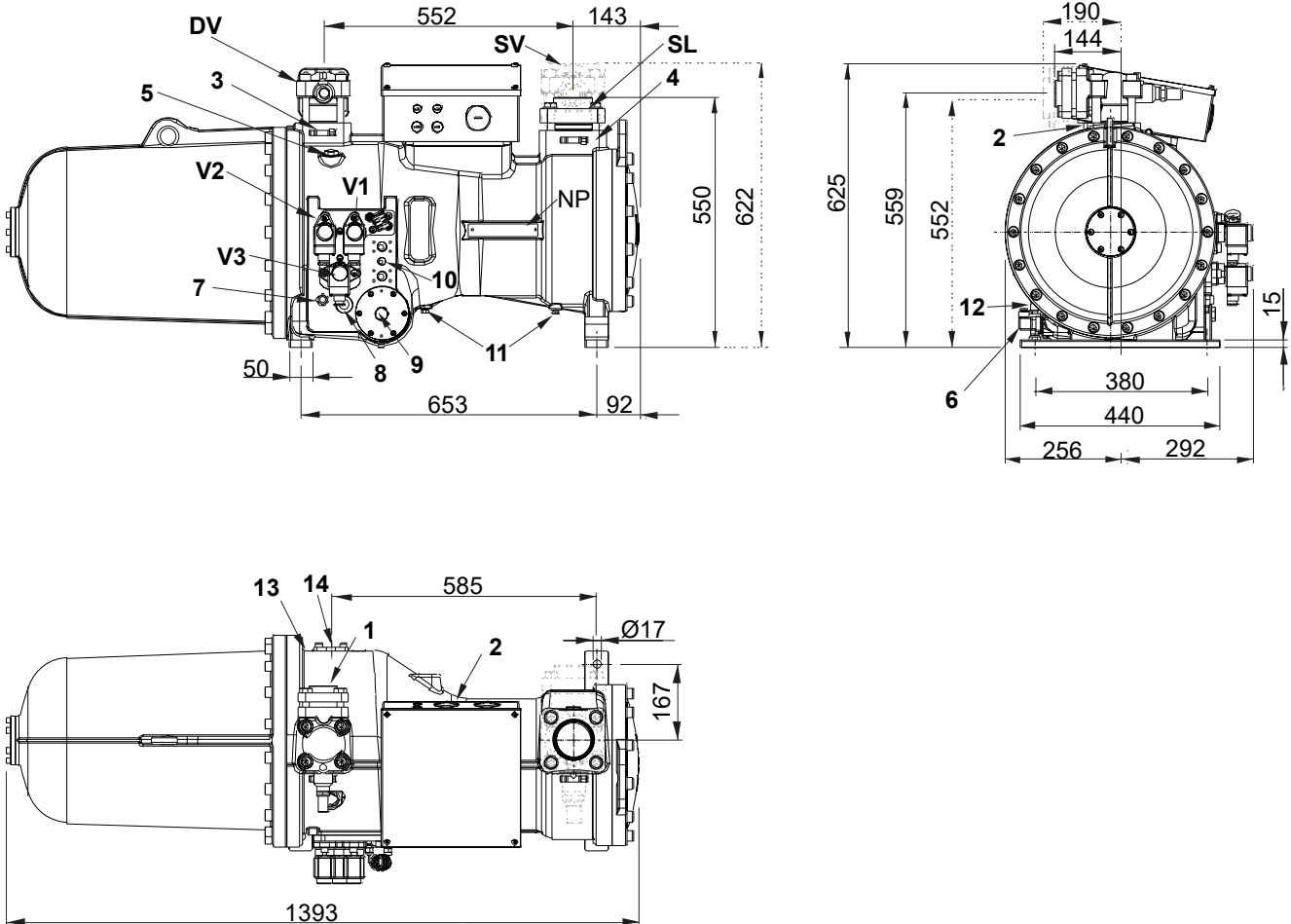

Legend:

SV: Suction Valve	3 1/8" in - 80 mm	6: Crankcase heater	-
DV: Discharge valve	2 1/8" in - 54 mm	7: Oil level regulator connection	3/4" NPT
SL: Suction line	3 1/8"	8: Oil level sight glass	-
V1: Capacity control valve	-	9: Filter clogging sensor connection	1/2" GAS
V2: Capacity control valve	-	10: Oil cooler connection	1/2" NPT
V3: Capacity control valve	-	11: Oil drain plug	1/4" NPT
1: High pressure connection	1/8" NPT	12: Oil drain valve	1/8" NPT
2: Low pressure connection	1/8" NPT	13: Maximum oil temperature sensor	-
3: High pressure connection	1/4" SAE x 1/4" SAE	14: ECO/liquid injection connection	1 1/8"
4: Low pressure connection	1/4" SAE x 1/4" SAE	NP: Nameplate	
5: Oil charge plug	3/8" GAS		

All data subject to change without notice

Model: CXH02-80-230Y

Refrigerant: R134a

Power supply: 400/3/50 PWS

Polynomial coefficients according to EN12900 for CXH02-80-230Y:

*S = T_{evap} ; D = T_{cond}

Reference conditions	
Refrigerant	R134a
Ambient temperature	35 °C
Suction gas superheating	10 K
Liquid subcooling	0 K
Frequency	50 Hz

	Refrigerating capacity [W]	Power input [W]
C1	1.686906E+005	2.211930E+004
C2	7.246260E+003	5.095679E+002
C3	5.001229E+001	3.284862E+002
C4	1.262076E+002	9.891445E+000
C5	-2.986706E+001	-4.733793E+000
C6	-3.459004E+001	-3.575703E+000
C7	9.182825E-001	1.083574E-001
C8	-9.908354E-001	-1.292276E-001
C9	-2.977506E-001	3.806812E-002
C10	1.916674E-001	9.460235E-002

$$Y = C1 + C2*S + C3*D + C4*S^2 + C5*S*D + C6*D^2 + C7*S^3 + C8*D*S^2 + C9*S*D^2 + C10*D^3$$