

Input data

Refrigerant	R449A	
Reference temperature	Dew point temperature	
Calculation mode	Refrigeration / Air Cond.	
Operating mode	Subcritical	
Power supply	400/3/50	
Condensing temperature	°C	45
Condensing pressure	bar	18.86
Liquid subcooling	K	2
Liquid temperature	°C	38.72
Evaporating temperature	°C	-5
Evaporating pressure	bar	4.33
Suction gas temperature	°C	20
Evaporator superheating	K	5

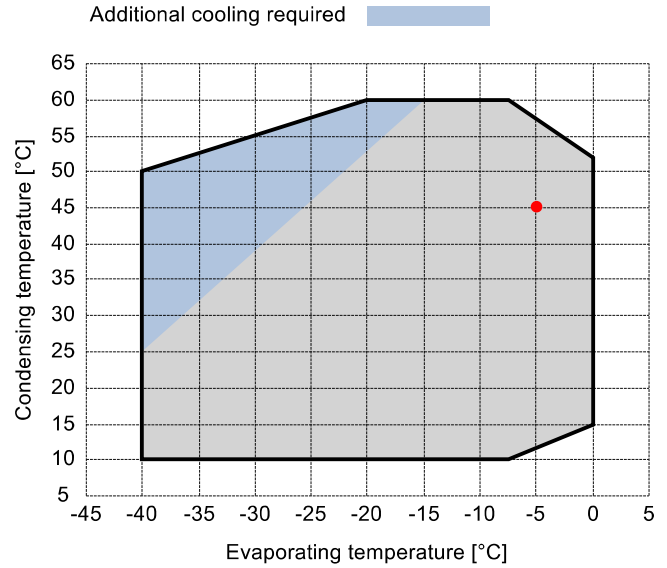

Output data

Compressor :	D3-16.1Y	
Number of compressors :	FSx1	
Refrigerating capacity	kW	10.251
Refrigerating capacity [*ref]	kW	10.036
Evaporator capacity	kW	9.079
Power input	W	3916
Condenser capacity, theor.	kW	14.167
Current	A	7.59
COP/EER	W/W	2.32
Mass flow	kg/h	230
Operating frequency	Hz	50
Connection	-	DOL-STAR
Operating mode	-	100%
Discharge temperature	°C	100.62
Ratio (%)	%	100.0%
Note	-	
Oil flow	l/min	-
Heat Exchanged (oil Cooler)	kW	-
Oil Temp. at Oil Cooler Outlet	°C	-
Certified by	-	Frascold

Certified by:

- Frascold tentative data

Legend:

- *ref: At conditions according to EN12900
- Suction gas temperature = 20 °C
- Liquid subcooling = 0 K

P&I Diagram:

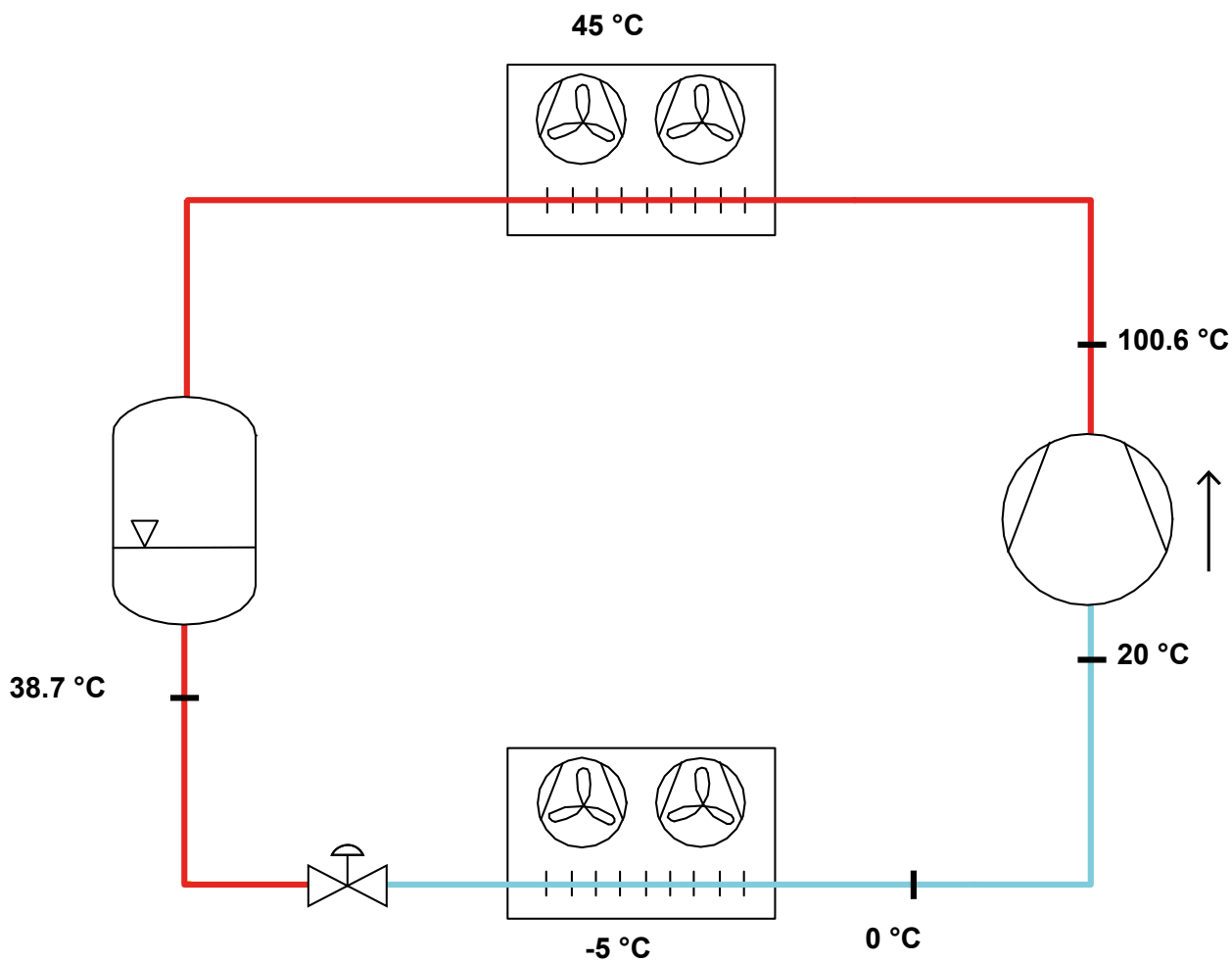

Model: D3-16.1Y

Refrigerant: R449A

Power supply: 400/3/50 DOL-STAR

Technical data:

Displacement	16.4 m³/h
Nominal compressor speed	1450 rpm
Motor voltage	400 V
Nominal operating frequency	50 Hz
Maximum allowed operating current (MRA)	9.9 A
Locked rotor current (LRA)	43.7 A
Number of pistons	2
Net weight	49 kg
Lubricant	FRASCOLD POE32
Oil charge	1.2 l
Maximum static pressure LP	20.5 bar
Maximum operating pressure HP	30 bar

Sound level:

Sound power level -10/45°C R404A @50Hz	67 dB(A)
Sound pressure (*) - Distance: 1 m	59 dB(A)
Sound power level -35/40°C R404A @50Hz	70 dB(A)
Sound pressure (*) - Distance: 1 m	62 dB(A)

*half sphere model

Motor connections:

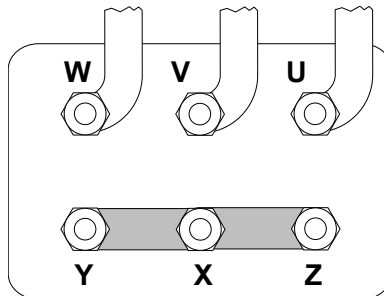

All data subject to change without notice

Model: D3-16.1Y

Refrigerant: R449A

Power supply: 400/3/50 DOL-STAR

Dimensions:

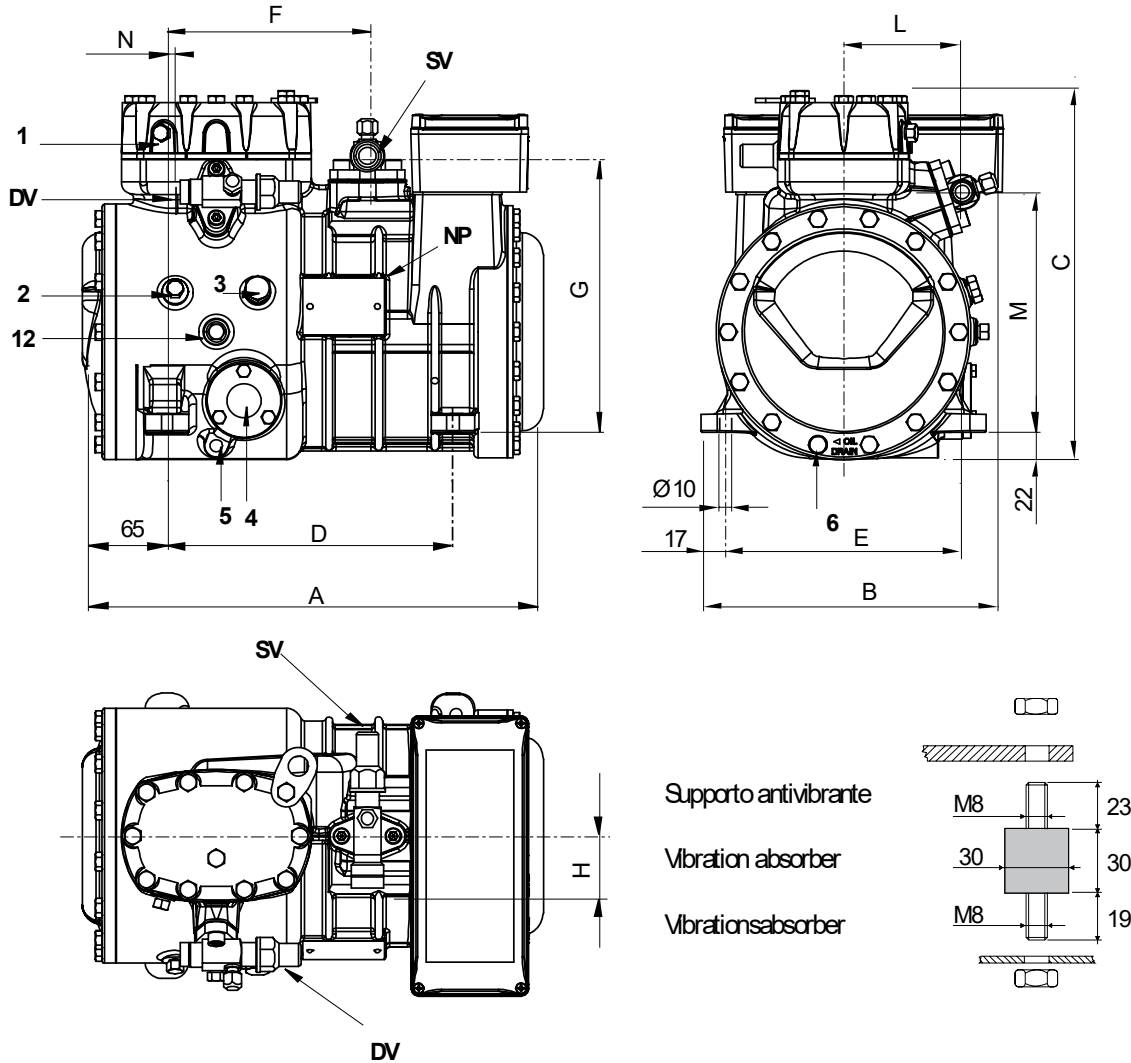

Legend:

SV: Suction Valve	1 1/8" in - 28.575 mm	M: Discharge valve	192 mm
DV: Discharge valve	5/8" in - 16 mm	N: Discharge valve	13 mm
A: Length	374 mm	1: High pressure connection	1/8" NPT
B: Width	242 mm	2: Low pressure connection	1/8" NPT
C: Height	317 mm	3: Oil charge plug	1/4" GAS
D: Base mounting	234 mm	4: Oil level sight glass	-
E: Base mounting	194 mm	5: Crankcase heater seat	-
F: Suction Valve	165 mm	6: Oil drain plug	M8 x 22
G: Suction Valve	225 mm	12: Oil return plug	1/8" NPT
H: Suction Valve	53 mm	NP: Nameplate	
I: Suction Valve	94 mm		

All data subject to change without notice

Model: D3-16.1Y

Refrigerant: R449A

Power supply: 400/3/50 DOL-STAR

Polynomial coefficients according to EN12900 for D3-16.1Y:

*S = T_{evap} ; D = T_{cond}

Reference conditions

Refrigerant	R449A
Ambient temperature	35 °C
Suction gas temperature	20 °C
Liquid subcooling	0 K
Frequency	50 Hz

	Refrigerating capacity [W]	Power input [W]
C1	2.115430E+004	8.088850E+002
C2	7.644240E+002	-7.205520E+001
C3	-2.057570E+002	9.265410E+001
C4	9.388520E+000	-2.297030E+000
C5	-6.438980E+000	3.035570E+000
C6	2.436490E-001	-3.845070E-001
C7	3.834190E-002	-1.930390E-002
C8	-5.756830E-002	2.230730E-002
C9	4.416720E-003	-6.608480E-003
C10	-1.092740E-003	2.151510E-005

$$Y = C1 + C2*S + C3*D + C4*S^2 + C5*S*D + C6*D^2 + C7*S^3 + C8*D*S^2 + C9*S*D^2 + C10*D^3$$