

## Input data

Refrigerant	R449A	
Reference temperature	Dew point temperature	
Calculation mode	Refrigeration / Air Cond.	
Operating mode	Subcritical	
Power supply	400/3/50	
Condensing temperature	°C	45
Condensing pressure	bar	18.86
Liquid subcooling	K	2
Liquid temperature	°C	38.72
Evaporating temperature	°C	-5
Evaporating pressure	bar	4.33
Suction gas temperature	°C	20
Evaporator superheating	K	5

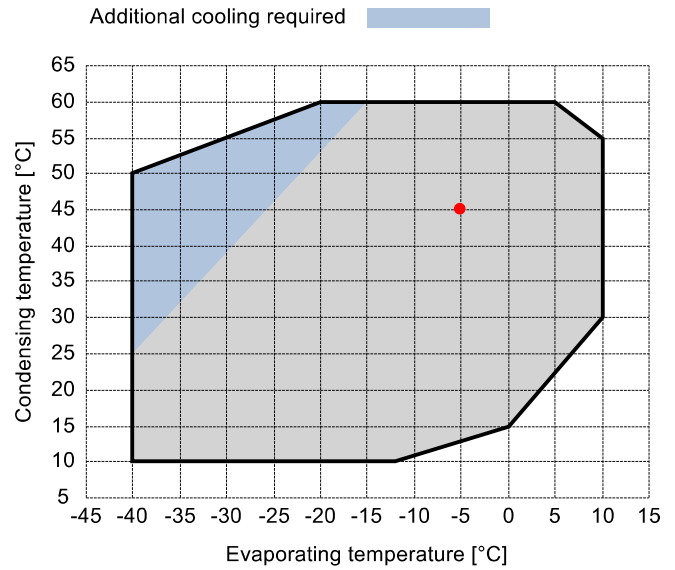

## Output data

<b>Compressor :</b>	<b>D4-18.1Y</b>	
Number of compressors :	FSx1	
Refrigerating capacity	kW	11.11
Refrigerating capacity [ *ref ]	kW	10.877
Evaporator capacity	kW	9.84
Power input	W	4136
Condenser capacity, theor.	kW	15.246
Current	A	8.74
COP/EER	W/W	2.38
Mass flow	kg/h	249
Operating frequency	Hz	50
Connection	-	DOL-STAR
Operating mode	-	100%
Discharge temperature	°C	99.2
Ratio (%)	%	100.0%
Note	-	
Oil flow	l/min	-
Heat Exchanged (oil Cooler)	kW	-
Oil Temp. at Oil Cooler Outlet	°C	-
Certified by	-	Frascold

### Certified by:

- Frascold tentative data

### Legend:

- \*ref: At conditions according to EN12900
- Suction gas temperature = 20 °C
- Liquid subcooling = 0 K

**P&I Diagram:**

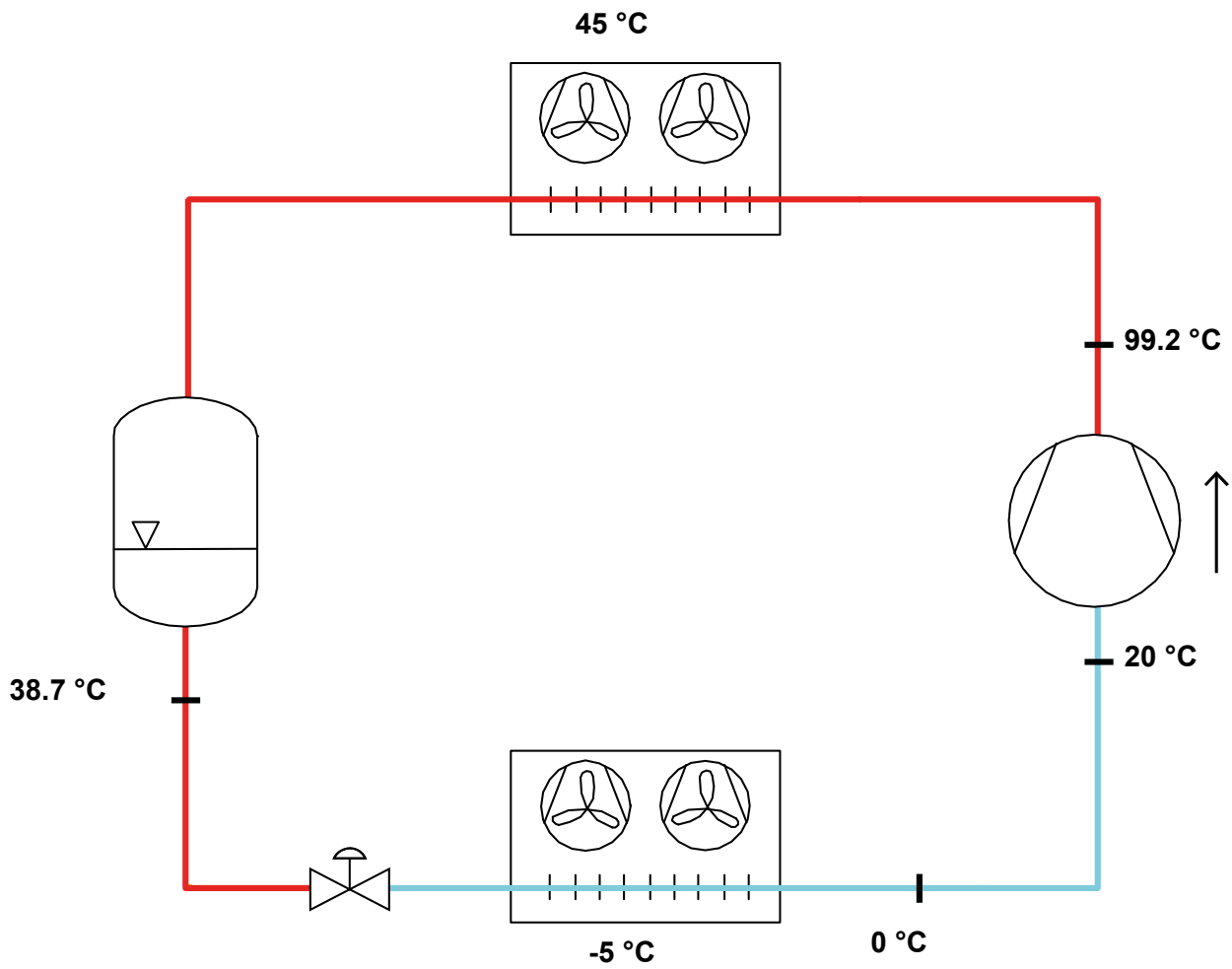

*All data subject to change without notice*

**Model: D4-18.1Y**

Refrigerant: R449A

Power supply: 400/3/50 DOL-STAR

**Technical data:**

Displacement	17.93 m³/h
Nominal compressor speed	1450 rpm
Motor voltage	400 V
Nominal operating frequency	50 Hz
Maximum allowed operating current (MRA)	12.5 A
Locked rotor current (LRA)	52 A
Number of pistons	2
Net weight	55 kg
Lubricant	FRASCOLD POE32
Oil charge	1.2 l
Maximum static pressure LP	20.5 bar
Maximum operating pressure HP	30 bar

**Sound level:**

Sound power level -10/45°C R404A @50Hz	67 dB(A)
Sound pressure (*) - Distance: 1 m	59 dB(A)
Sound power level -35/40°C R404A @50Hz	70.3 dB(A)
Sound pressure (*) - Distance: 1 m	62.3 dB(A)

\*half sphere model

**Motor connections:**

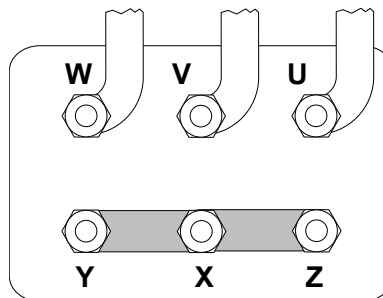

*All data subject to change without notice*

**Model: D4-18.1Y**

Refrigerant: R449A

Power supply: 400/3/50 DOL-STAR

**Dimensions:**

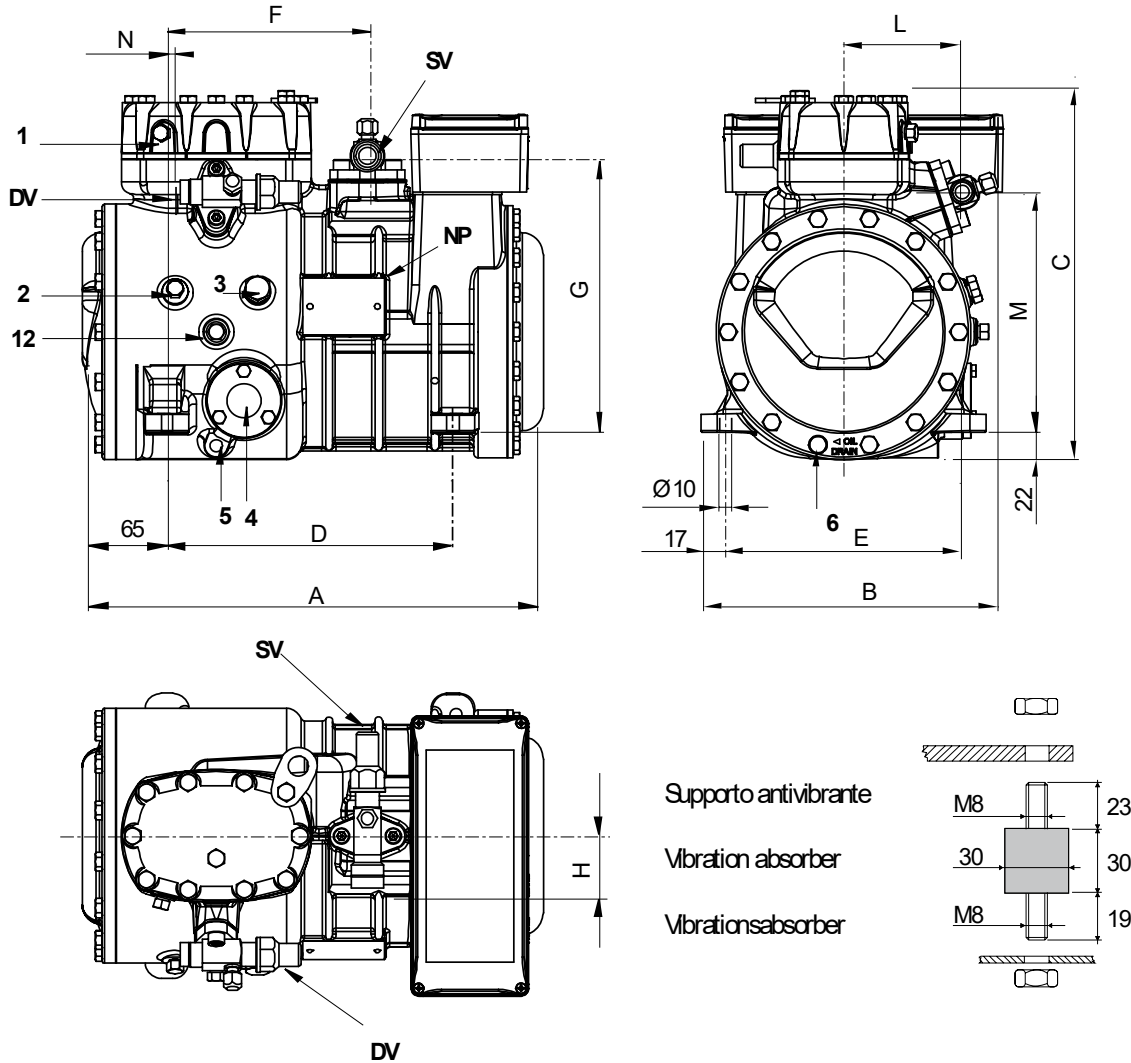

**Legend:**

SV: Suction Valve	1 1/8" in - 28.575 mm	M: Discharge valve	192 mm
DV: Discharge valve	3/4" in - 19 mm	N: Discharge valve	5 mm
A: Length	401 mm	1: High pressure connection	1/8" NPT
B: Width	242 mm	2: Low pressure connection	1/8" NPT
C: Height	317 mm	3: Oil charge plug	1/4" GAS
D: Base mounting	234 mm	4: Oil level sight glass	-
E: Base mounting	194 mm	5: Crankcase heater seat	-
F: Suction Valve	165 mm	6: Oil drain plug	M8 x 22
G: Suction Valve	225 mm	12: Oil return plug	1/8" NPT
H: Suction Valve	53 mm	NP: Nameplate	
I: Discharge valve	94 mm		

All data subject to change without notice

**Model: D4-18.1Y**

Refrigerant: R449A

Power supply: 400/3/50 DOL-STAR

**Polynomial coefficients according to EN12900 for D4-18.1Y:**

\*S = T<sub>evap</sub> ; D = T<sub>cond</sub>

Reference conditions

Refrigerant	R449A
Ambient temperature	35 °C
Suction gas temperature	20 °C
Liquid subcooling	0 K
Frequency	50 Hz

	Refrigerating capacity [W]	Power input [W]
<b>C1</b>	2.287170E+004	9.160510E+002
<b>C2</b>	8.414410E+002	-7.090110E+001
<b>C3</b>	-2.124480E+002	9.867330E+001
<b>C4</b>	1.118580E+001	-2.120030E+000
<b>C5</b>	-6.825530E+000	2.969060E+000
<b>C6</b>	-2.250730E-002	-4.903730E-001
<b>C7</b>	5.694910E-002	-1.496330E-002
<b>C8</b>	-6.338210E-002	2.218800E-002
<b>C9</b>	2.733640E-003	-4.582540E-003
<b>C10</b>	1.197350E-003	7.205420E-004

$$Y = C1 + C2*S + C3*D + C4*S^2 + C5*S*D + C6*D^2 + C7*S^3 + C8*D*S^2 + C9*S*D^2 + C10*D^3$$