

## Input data

Refrigerant	R449A	
Reference temperature	Dew point temperature	
Calculation mode	Refrigeration / Air Cond.	
Operating mode	Subcritical	
Power supply	400/3/50	
Condensing temperature	°C	45
Condensing pressure	bar	18.86
Liquid subcooling	K	2
Liquid temperature	°C	38.72
Evaporating temperature	°C	-5
Evaporating pressure	bar	4.33
Suction gas temperature	°C	20
Evaporator superheating	K	5

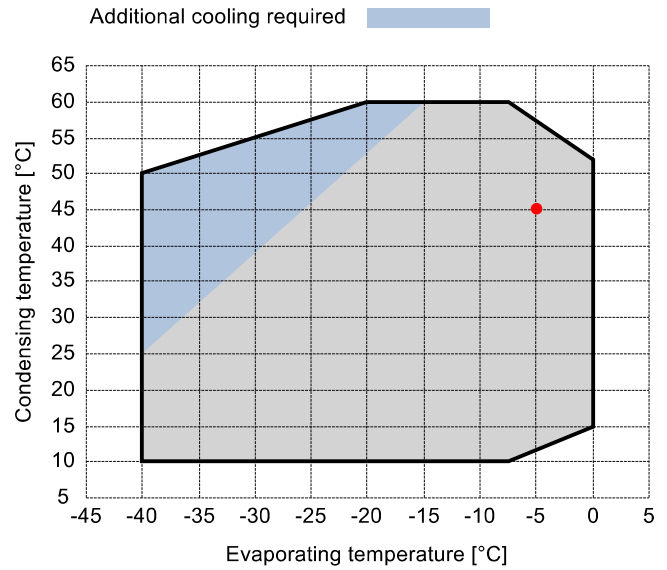

## Output data

<b>Compressor :</b>		<b>A1.5-8Y</b>
Number of compressors :		FSx1
Refrigerating capacity	kW	4.362
Refrigerating capacity [ *ref ]	kW	4.27
Evaporator capacity	kW	3.863
Power input	W	1779
Condenser capacity, theor.	kW	6.14
Current	A	3.67
COP/EER	W/W	2.17
Mass flow	kg/h	98
Operating frequency	Hz	50
Connection	-	DOL-STAR
Operating mode	-	100%
Discharge temperature	°C	104.36
Ratio (%)	%	100.0%
Note	-	
Oil flow	l/min	-
Heat Exchanged (oil Cooler)	kW	-
Oil Temp. at Oil Cooler Outlet	°C	-
Certified by	-	Frascold

## Certified by:

- Frascold tentative data

## Legend:

- \*ref: At conditions according to EN12900
- Suction gas temperature = 20 °C
- Liquid subcooling = 0 K

**P&I Diagram:**

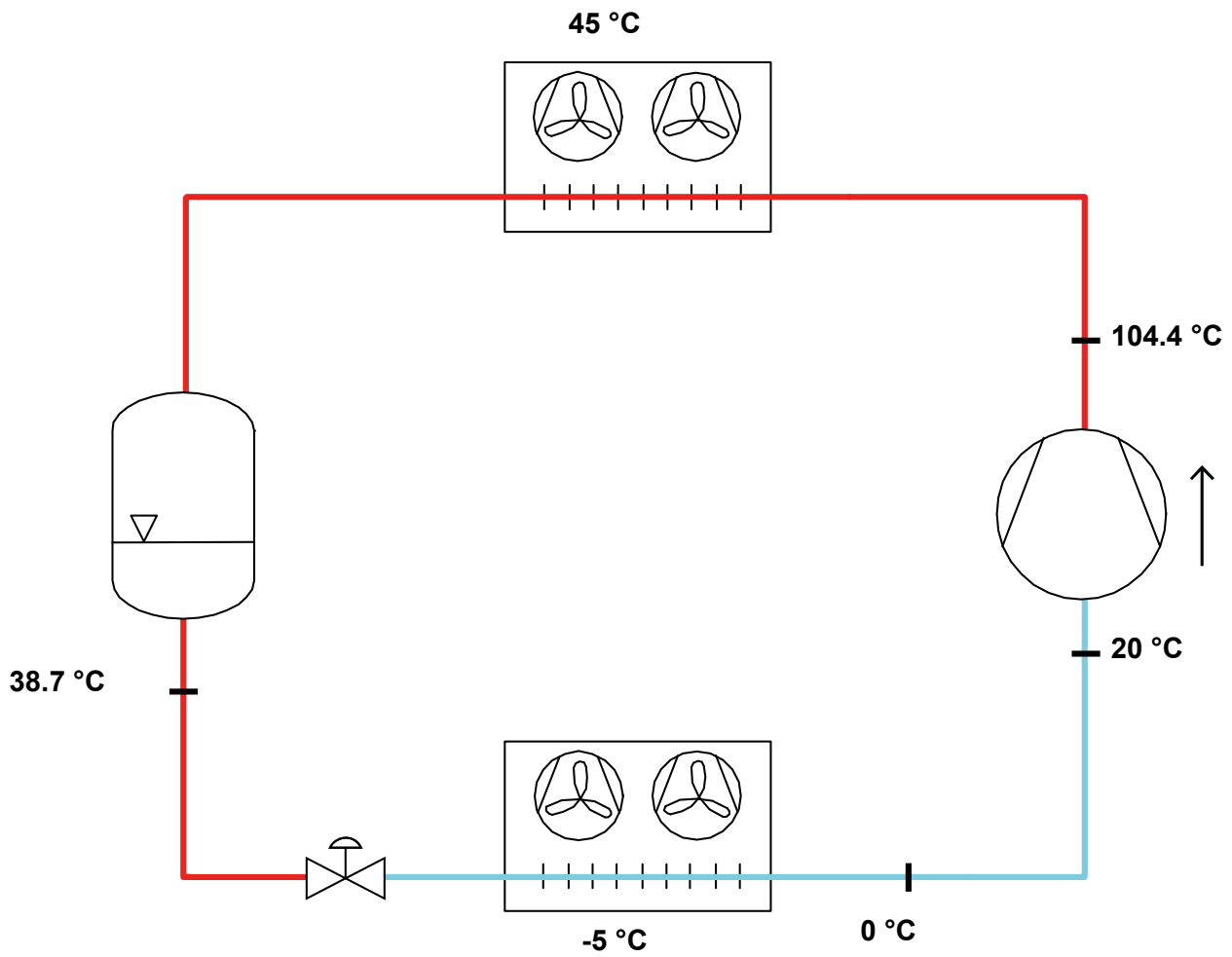

*All data subject to change without notice*

**Model: A1.5-8Y**

Refrigerant: R449A

Power supply: 400/3/50 DOL-STAR

**Technical data:**

Displacement	7.65 m³/h
Nominal compressor speed	1450 rpm
Motor voltage	400 V
Nominal operating frequency	50 Hz
Maximum allowed operating current (MRA)	4.8 A
Locked rotor current (LRA)	20.6 A
Number of pistons	2
Net weight	36 kg
Lubricant	FRASCOLD POE32
Oil charge	1 l
Maximum static pressure LP	20.5 bar
Maximum operating pressure HP	30 bar

**Sound level:**

Sound power level 5/50°C R404A @50Hz	64 dB(A)
Sound pressure (*) - Distance: 1 m	56 dB(A)
Sound power level -10/45°C R404A @50Hz	63 dB(A)
Sound pressure (*) - Distance: 1 m	55 dB(A)
Sound power level -35/40°C R404A @50Hz	63.5 dB(A)
Sound pressure (*) - Distance: 1 m	55.5 dB(A)

\*half sphere model

**Motor connections:**

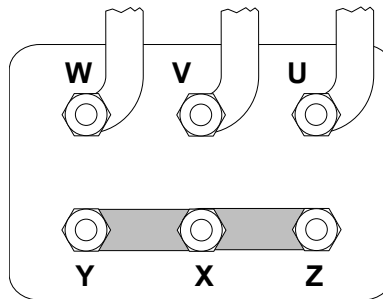

*All data subject to change without notice*

**Model: A1.5-8Y**

Refrigerant: R449A

Power supply: 400/3/50 DOL-STAR

**Dimensions:**

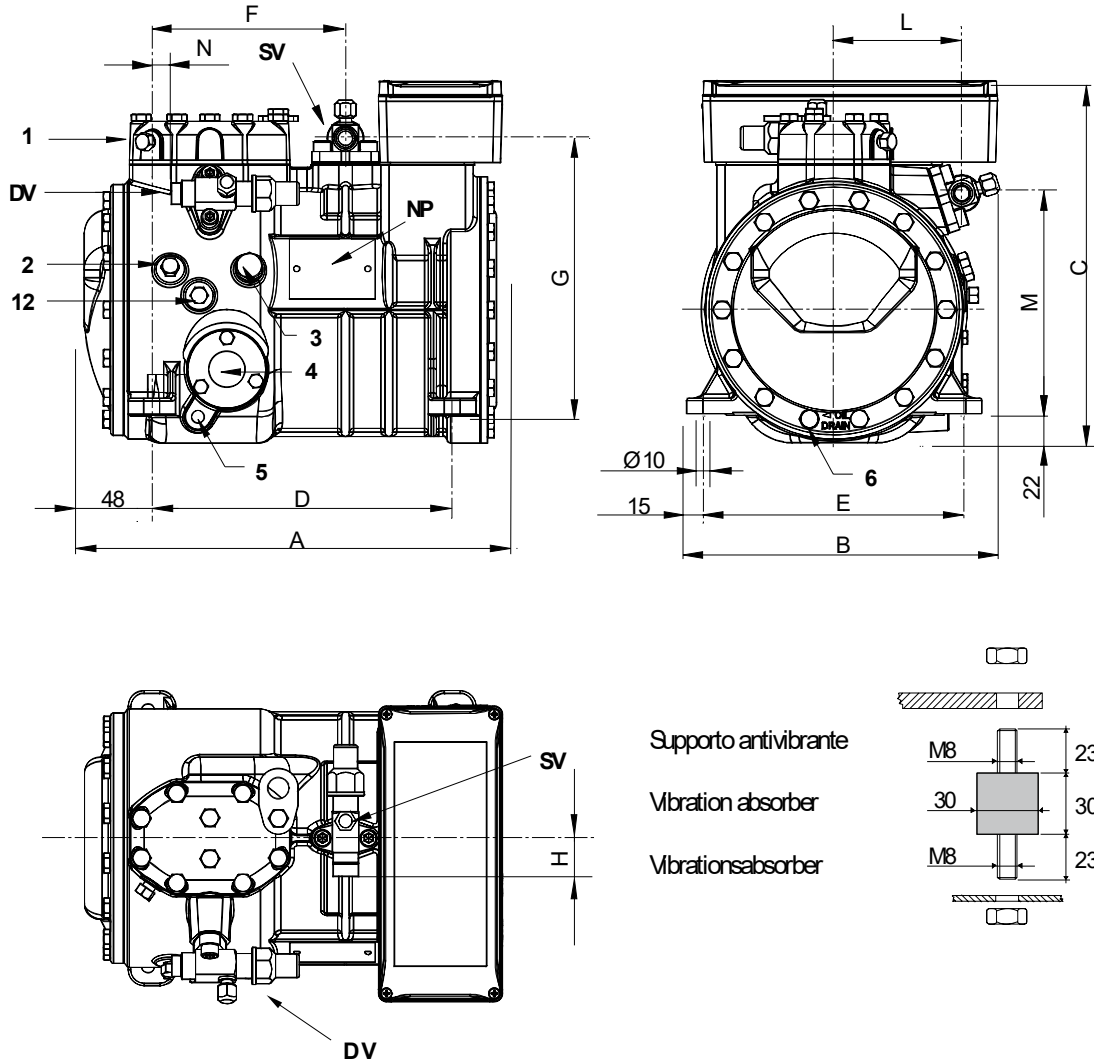

**Legend:**

SV: Suction Valve	5/8" in - 16 mm	M: Discharge valve	167 mm
DV: Discharge valve	1/2" in - 12.7 mm	N: Discharge valve	18 mm
A: Length	317 mm	1: High pressure connection	1/8" NPT
B: Width	237 mm	2: Low pressure connection	1/8" NPT
C: Height	275 mm	3: Oil charge plug	1/4" GAS
D: Base mounting	234 mm	4: Oil level sight glass	-
E: Base mounting	194 mm	5: Crankcase heater seat	-
F: Suction Valve	150 mm	6: Oil drain plug	M8 x 22
G: Suction Valve	209 mm	12: Oil return plug	1/8" NPT
H: Suction Valve	29 mm	NP: Nameplate	
L: Discharge valve	97 mm		

All data subject to change without notice

**Model: A1.5-8Y**

Refrigerant: R449A

Power supply: 400/3/50 DOL-STAR

**Polynomial coefficients according to EN12900 for A1.5-8Y:**

\*S = T<sub>evap</sub> ; D = T<sub>cond</sub>

Reference conditions

Refrigerant	R449A
Ambient temperature	35 °C
Suction gas temperature	20 °C
Liquid subcooling	0 K
Frequency	50 Hz

	Refrigerating capacity [W]	Power input [W]
<b>C1</b>	9.186950E+003	-2.788240E+001
<b>C2</b>	3.714580E+002	-5.178220E+001
<b>C3</b>	-6.906210E+001	8.034640E+001
<b>C4</b>	5.034350E+000	-1.543450E+000
<b>C5</b>	-3.405920E+000	1.934440E+000
<b>C6</b>	-5.212360E-001	-1.223100E+000
<b>C7</b>	2.295460E-002	-1.017830E-002
<b>C8</b>	-3.780430E-002	1.872510E-002
<b>C9</b>	5.089090E-004	-7.238270E-003
<b>C10</b>	2.878670E-003	8.635910E-003

$$Y = C1 + C2*S + C3*D + C4*S^2 + C5*S*D + C6*D^2 + C7*S^3 + C8*D*S^2 + C9*S*D^2 + C10*D^3$$