

## Input data

Refrigerant	R449A	
Reference temperature	Dew point temperature	
Calculation mode	Refrigeration / Air Cond.	
Operating mode	Subcritical	
Power supply	400/3/50	
Condensing temperature	°C	45
Condensing pressure	bar	18.86
Liquid subcooling	K	2
Liquid temperature	°C	38.72
Evaporating temperature	°C	-5
Evaporating pressure	bar	4.33
Suction gas temperature	°C	20
Evaporator superheating	K	5

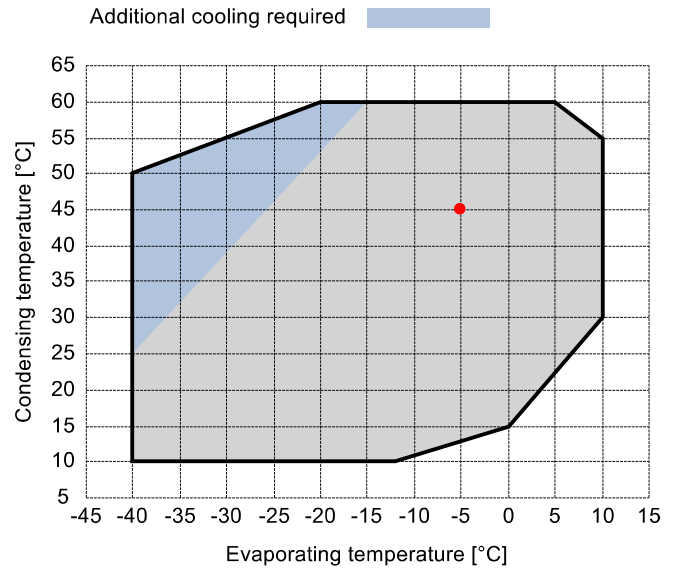

## Output data

<b>Compressor :</b>		<b>D3-13.1Y</b>
Number of compressors :		FSx1
Refrigerating capacity	kW	8.069
Refrigerating capacity [ *ref ]	kW	7.9
Evaporator capacity	kW	7.147
Power input	W	3029
Condenser capacity, theor.	kW	11.098
Current	A	6.57
COP/EER	W/W	2.36
Mass flow	kg/h	181
Operating frequency	Hz	50
Connection	-	DOL-STAR
Operating mode	-	100%
Discharge temperature	°C	99.65
Ratio (%)	%	100.0%
Note	-	
Oil flow	l/min	-
Heat Exchanged (oil Cooler)	kW	-
Oil Temp. at Oil Cooler Outlet	°C	-
Certified by	-	Frascold

## Certified by:

- Frascold tentative data

## Legend:

- \*ref: At conditions according to EN12900
- Suction gas temperature = 20 °C
- Liquid subcooling = 0 K

**P&I Diagram:**

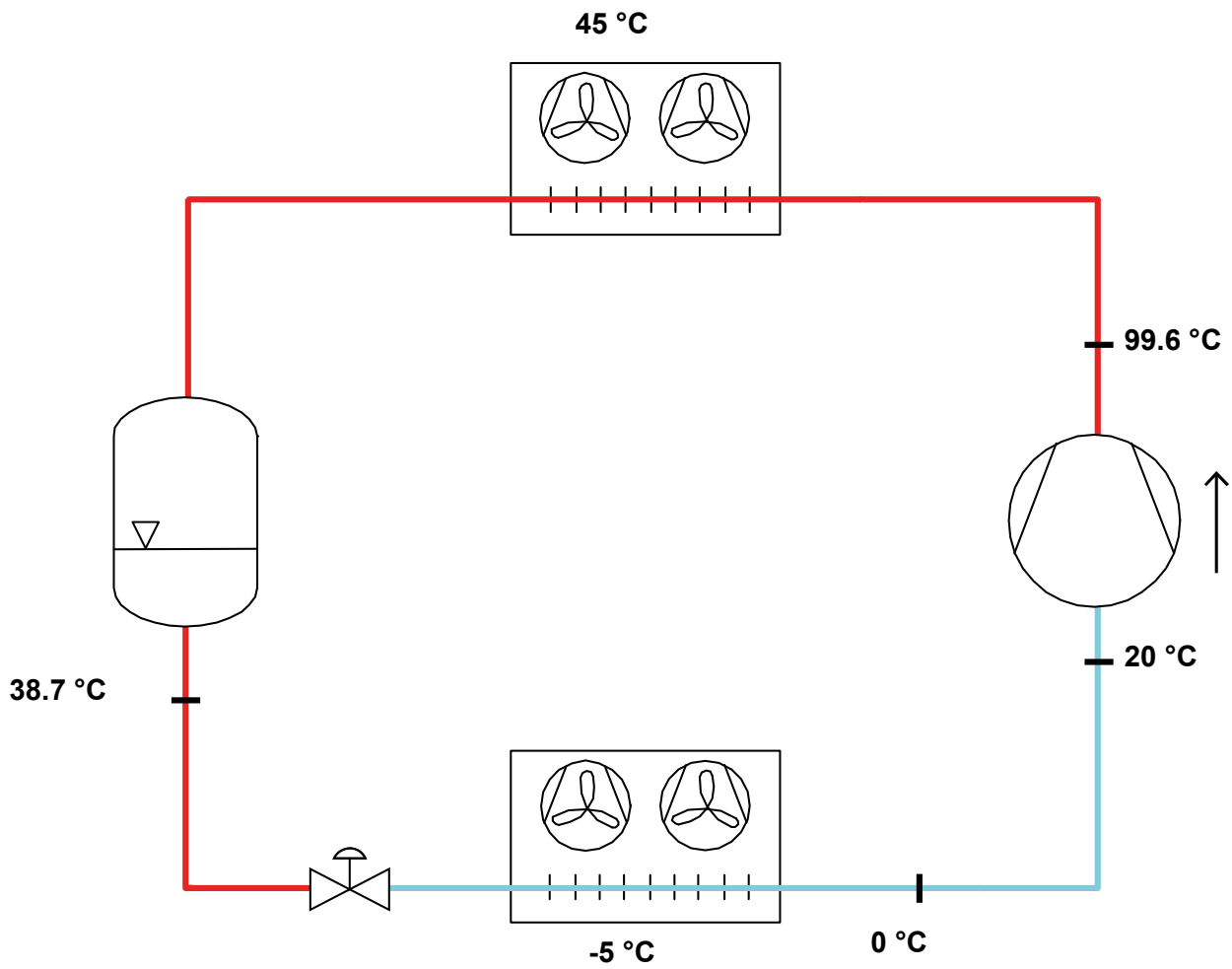

*All data subject to change without notice*

**Model: D3-13.1Y**

Refrigerant: R449A

Power supply: 400/3/50 DOL-STAR

**Technical data:**

Displacement	13.15 m³/h
Nominal compressor speed	1450 rpm
Motor voltage	400 V
Nominal operating frequency	50 Hz
Maximum allowed operating current (MRA)	8.8 A
Locked rotor current (LRA)	43.7 A
Number of pistons	2
Net weight	49 kg
Lubricant	FRASCOLD POE32
Oil charge	1.2 l
Maximum static pressure LP	20.5 bar
Maximum operating pressure HP	30 bar

**Sound level:**

Sound power level 5/50°C R404A @50Hz	67 dB(A)
Sound pressure (*) - Distance: 1 m	59 dB(A)
Sound power level -10/45°C R404A @50Hz	66.5 dB(A)
Sound pressure (*) - Distance: 1 m	58.5 dB(A)

\*half sphere model

**Motor connections:**

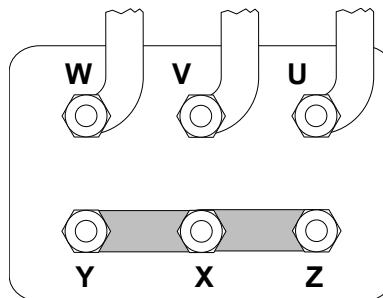

*All data subject to change without notice*

**Model: D3-13.1Y**

Refrigerant: R449A

Power supply: 400/3/50 DOL-STAR

**Dimensions:**

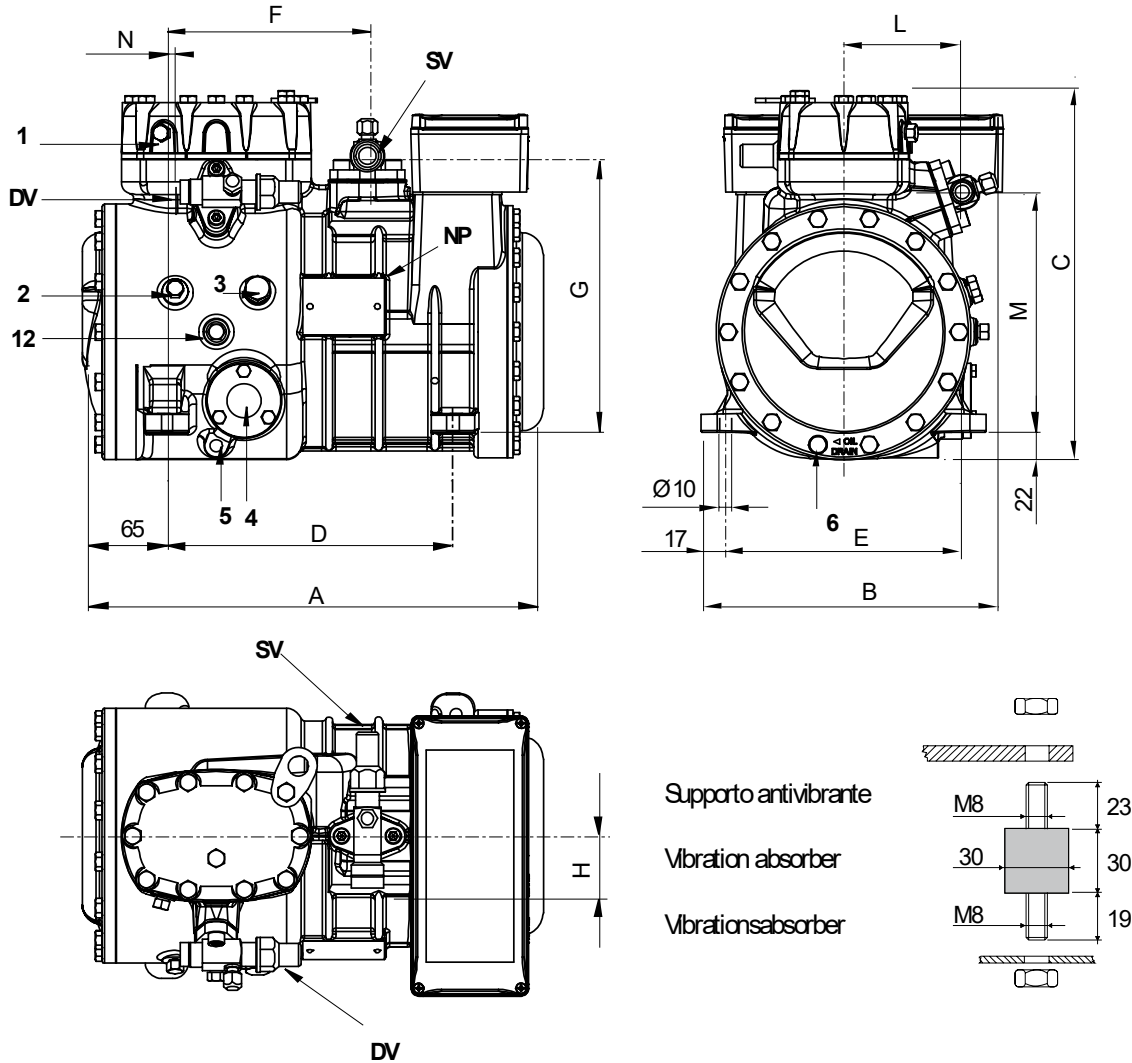

**Legend:**

SV: Suction Valve	1 1/8" in - 28.575 mm	M: Discharge valve	192 mm
DV: Discharge valve	5/8" in - 16 mm	N: Discharge valve	13 mm
A: Length	374 mm	1: High pressure connection	1/8" NPT
B: Width	242 mm	2: Low pressure connection	1/8" NPT
C: Height	317 mm	3: Oil charge plug	1/4" GAS
D: Base mounting	234 mm	4: Oil level sight glass	-
E: Base mounting	194 mm	5: Crankcase heater seat	-
F: Suction Valve	165 mm	6: Oil drain plug	M8 x 22
G: Suction Valve	225 mm	12: Oil return plug	1/8" NPT
H: Suction Valve	53 mm	NP: Nameplate	
L: Discharge valve	94 mm		

All data subject to change without notice

**Model: D3-13.1Y**

Refrigerant: R449A

Power supply: 400/3/50 DOL-STAR

**Polynomial coefficients according to EN12900 for D3-13.1Y:**

\*S = T<sub>evap</sub> ; D = T<sub>cond</sub>

Reference conditions

Refrigerant	R449A
Ambient temperature	35 °C
Suction gas temperature	20 °C
Liquid subcooling	0 K
Frequency	50 Hz

	Refrigerating capacity [W]	Power input [W]
<b>C1</b>	1.673870E+004	8.109650E+002
<b>C2</b>	6.233910E+002	-5.000290E+001
<b>C3</b>	-1.561710E+002	5.890420E+001
<b>C4</b>	8.354850E+000	-1.664190E+000
<b>C5</b>	-5.009660E+000	2.009400E+000
<b>C6</b>	5.960430E-002	4.150350E-002
<b>C7</b>	4.117730E-002	-1.292550E-002
<b>C8</b>	-5.104420E-002	1.604310E-002
<b>C9</b>	-8.065990E-004	-8.829400E-005
<b>C10</b>	-1.057630E-003	-3.224560E-003

$$Y = C1 + C2*S + C3*D + C4*S^2 + C5*S*D + C6*D^2 + C7*S^3 + C8*D*S^2 + C9*S*D^2 + C10*D^3$$