

## Input data

Refrigerant	R449A	
Reference temperature	Dew point temperature	
Calculation mode	Refrigeration / Air Cond.	
Operating mode	Subcritical	
Power supply	400/3/50	
Condensing temperature	°C	45
Condensing pressure	bar	18.86
Liquid subcooling	K	2
Liquid temperature	°C	38.72
Evaporating temperature	°C	-5
Evaporating pressure	bar	4.33
Suction gas temperature	°C	20
Evaporator superheating	K	5

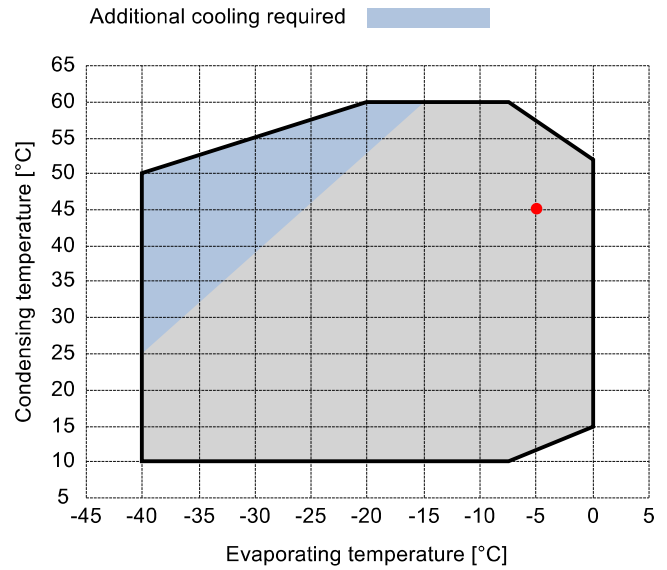

## Output data

<b>Compressor :</b>	<b>Q5-33.1Y</b>	
Number of compressors :	FSx1	
Refrigerating capacity	kW	19.051
Refrigerating capacity [ *ref ]	kW	18.652
Evaporator capacity	kW	16.874
Power input	W	7368
Condenser capacity, theor.	kW	26.419
Current	A	11.88
COP/EER	W/W	2.29
Mass flow	kg/h	427
Operating frequency	Hz	50
Connection	-	DOL-STAR
Operating mode	-	100%
Discharge temperature	°C	101.3
Ratio (%)	%	100.0%
Note	-	
Oil flow	l/min	-
Heat Exchanged (oil Cooler)	kW	-
Oil Temp. at Oil Cooler Outlet	°C	-
Certified by	-	ASERCOM

### Certified by:

- ASERCOM (ref. EN12900, 50 Hz, 100% cap.)



### Legend:

- \*ref: At conditions according to EN12900
- Suction gas temperature = 20 °C
- Liquid subcooling = 0 K

All data subject to change without notice

**P&I Diagram:**

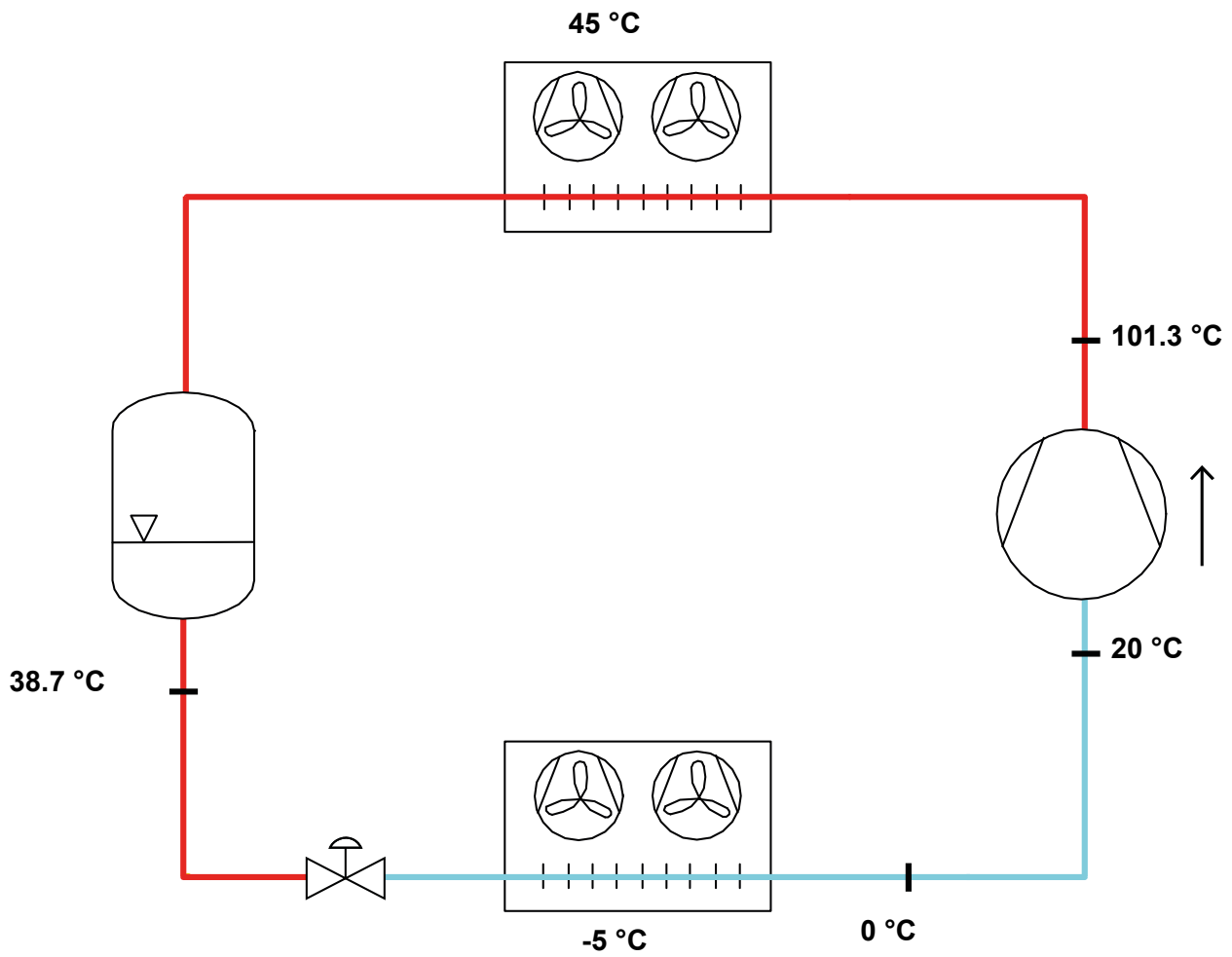

*All data subject to change without notice*

**Model: Q5-33.1Y**

Refrigerant: R449A

Power supply: 400/3/50 DOL-STAR

**Technical data:**

Displacement	32.66 m³/h
Nominal compressor speed	1450 rpm
Motor voltage	400 V
Nominal operating frequency	50 Hz
Maximum allowed operating current (MRA)	14.4 A
Locked rotor current (LRA)	63.1 A
Number of pistons	4
Net weight	79 kg
Lubricant	FRASCOLD POE32
Oil charge	1.6 l
Maximum static pressure LP	20.5 bar
Maximum operating pressure HP	30 bar

**Sound level:**

Sound power level -10/45°C R404A @50Hz	72.5 dB(A)
Sound pressure (*) - Distance: 1 m	64.5 dB(A)
Sound power level -35/40°C R404A @50Hz	76 dB(A)
Sound pressure (*) - Distance: 1 m	68 dB(A)

\*half sphere model

**Motor connections:**

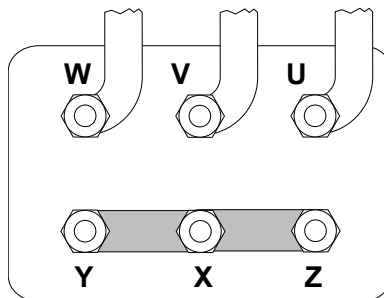

*All data subject to change without notice*

**Model: Q5-33.1Y**

Refrigerant: R449A

Power supply: 400/3/50 DOL-STAR

**Dimensions:**

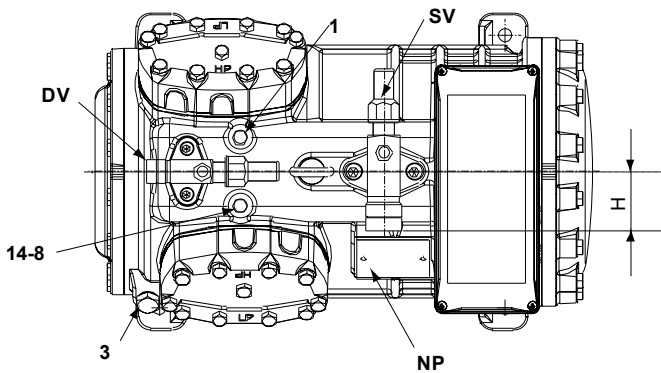
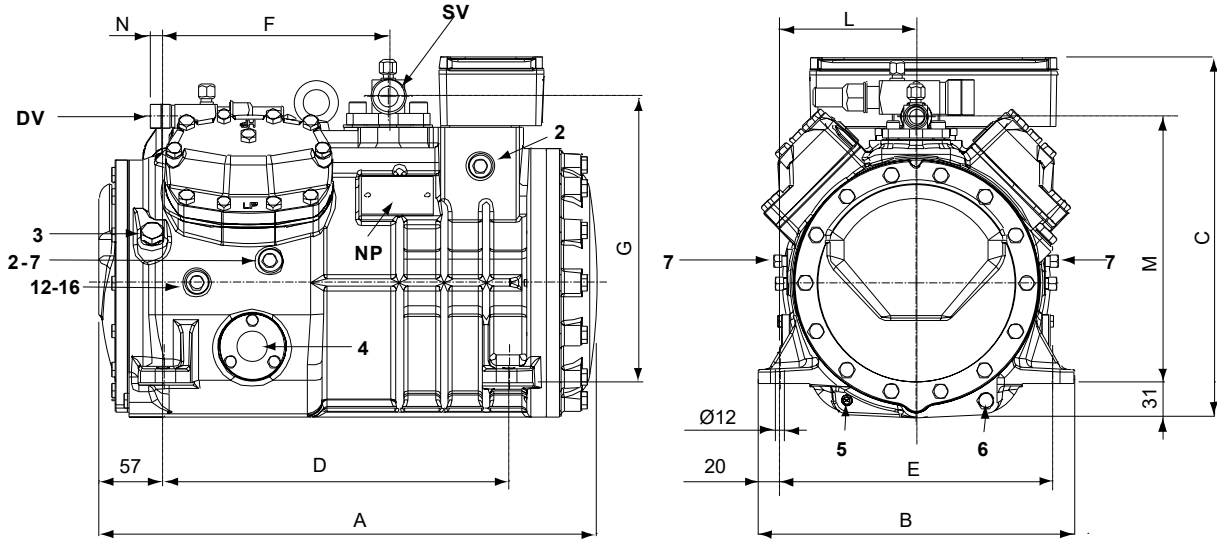

Supporto antivibrante

Vibration absorber

Vibrationsabsorber

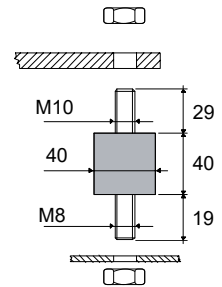

**Legend:**

SV: Suction Valve	1 3/8" in - 35 mm	1: High pressure connection	1/8" NPT
DV: Discharge valve	1 1/8" in - 28.575 mm	2: Low pressure connection	1/8" NPT
A: Length	449 mm	3: Oil charge plug	1/4" GAS
B: Width	286 mm	4: Oil level sight glass	-
C: Height	328 mm	5: Crankcase heater seat	-
D: Base mounting	312 mm	6: Oil drain plug	M8 x 22
E: Base mounting	246 mm	7: Liquid injection plug	1/8" NPT
F: Suction Valve	203 mm	8: Liquid injection sensor plug	1/8" NPT
G: Suction Valve	261 mm	12: Oil return plug	1/8" NPT
H: Suction Valve	58 mm	14: Max discharge temperature sensor connection	1/8" NPT
L: Discharge valve	123 mm	16: Crankcase pressure plug	1/8" NPT
M: Discharge valve	239 mm	NP: Nameplate	
N: Discharge valve	28 mm		

All data subject to change without notice

**Model: Q5-33.1Y**

Refrigerant: R449A

Power supply: 400/3/50 DOL-STAR

**Polynomial coefficients according to EN12900 for Q5-33.1Y:**

\*S = T<sub>evap</sub> ; D = T<sub>cond</sub>

Reference conditions

Refrigerant	R449A
Ambient temperature	35 °C
Suction gas temperature	20 °C
Liquid subcooling	0 K
Frequency	50 Hz

	Refrigerating capacity [W]	Power input [W]
<b>C1</b>	4.332380E+004	2.722278E+003
<b>C2</b>	1.686090E+003	-5.441031E+001
<b>C3</b>	-5.616660E+002	1.123635E+002
<b>C4</b>	2.274740E+001	-2.280808E+000
<b>C5</b>	-2.028040E+001	3.093598E+000
<b>C6</b>	3.097830E+000	3.478325E-001
<b>C7</b>	9.443980E-002	-1.392705E-002
<b>C8</b>	-2.216530E-001	2.088332E-002
<b>C9</b>	5.227950E-002	1.089999E-002
<b>C10</b>	-1.734620E-002	-6.025875E-003

$$Y = C1 + C2*S + C3*D + C4*S^2 + C5*S*D + C6*D^2 + C7*S^3 + C8*D*S^2 + C9*S*D^2 + C10*D^3$$