

## Input data

Refrigerant	R449A	
Reference temperature	Dew point temperature	
Calculation mode	Refrigeration / Air Cond.	
Operating mode	Subcritical	
Power supply	400/3/50	
Condensing temperature	°C	45
Condensing pressure	bar	18.86
Liquid subcooling	K	2
Liquid temperature	°C	38.72
Evaporating temperature	°C	-5
Evaporating pressure	bar	4.33
Suction gas temperature	°C	20
Evaporator superheating	K	5

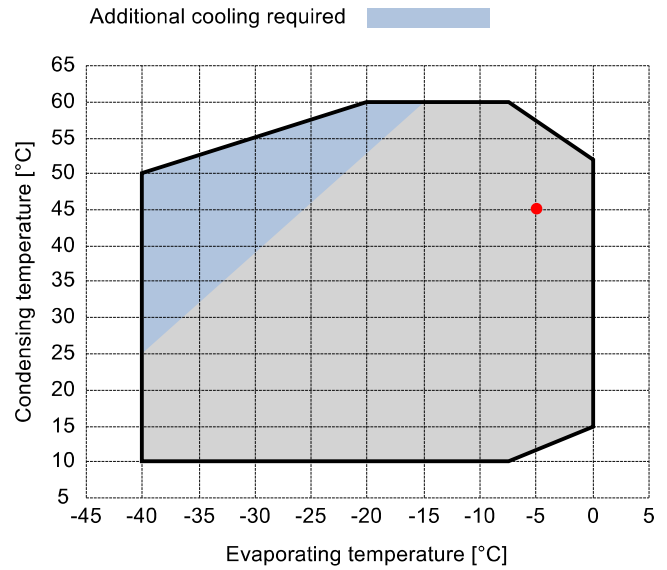

## Output data

<b>Compressor :</b>	<b>S10-52Y</b>	
Number of compressors :	FSx1	
Refrigerating capacity	kW	30.743
Refrigerating capacity [ *ref ]	kW	30.098
Evaporator capacity	kW	27.229
Power input	W	10742
Condenser capacity, theor.	kW	41.484
Current	A	18.19
COP/EER	W/W	2.53
Mass flow	kg/h	689
Operating frequency	Hz	50
Connection	-	PWS
Operating mode	-	100%
Discharge temperature	°C	95.9
Ratio (%)	%	100.0%
Note	-	
Oil flow	l/min	-
Heat Exchanged (oil Cooler)	kW	-
Oil Temp. at Oil Cooler Outlet	°C	-
Certified by	-	Frascold

## Certified by:

- Frascold tentative data

## Legend:

- \*ref: At conditions according to EN12900
- Suction gas temperature = 20 °C
- Liquid subcooling = 0 K

**P&I Diagram:**

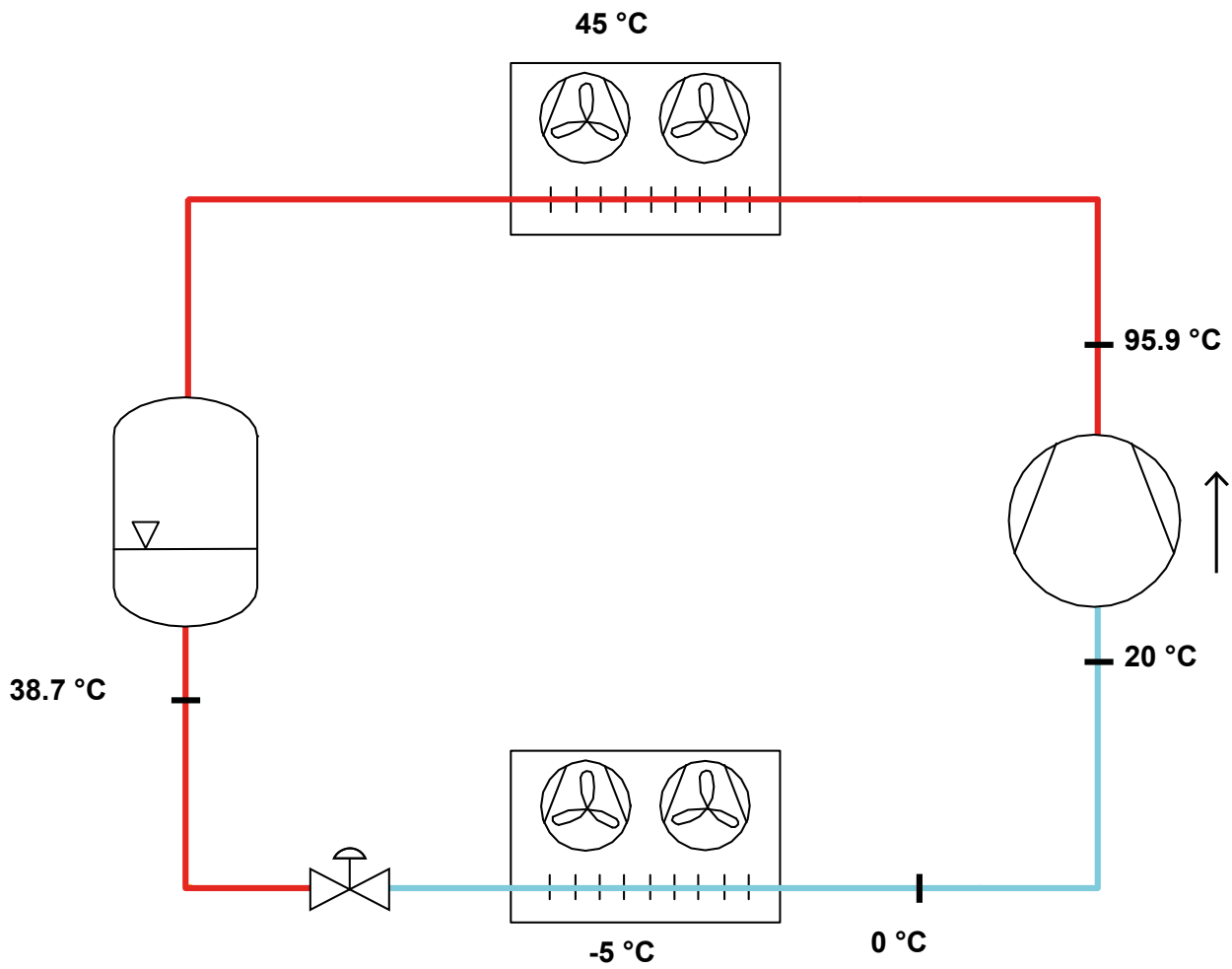

**Model: S10-52Y**

Refrigerant: R449A

Power supply: 400/3/50 PWS

**Technical data:**

Displacement	51.5 m³/h
Nominal compressor speed	1450 rpm
Motor voltage	400 V
Nominal operating frequency	50 Hz
Maximum allowed operating current (MRA)	24.5 A
Locked rotor current (LRA)	59.1 A
Locked rotor current (LRA), DOL	102.29 A
Number of pistons	4
Net weight	120 kg
Lubricant	FRASCOLD POE32
Oil charge	2.9 l
Maximum static pressure LP	20.5 bar
Maximum operating pressure HP	30 bar

**Sound level:**

Sound power level -10/45°C R404A @50Hz	76.5 dB(A)
Sound pressure (*) - Distance: 1 m	68.5 dB(A)
Sound power level -35/40°C R404A @50Hz	81 dB(A)
Sound pressure (*) - Distance: 1 m	73 dB(A)

\*half sphere model

**Motor connections:**

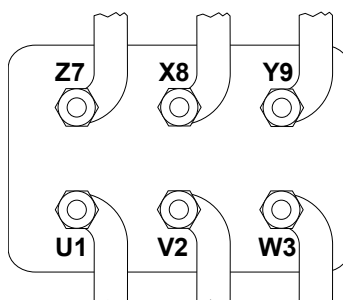

*All data subject to change without notice*

**Model: S10-52Y**

Refrigerant: R449A

Power supply: 400/3/50 PWS

**Dimensions:**

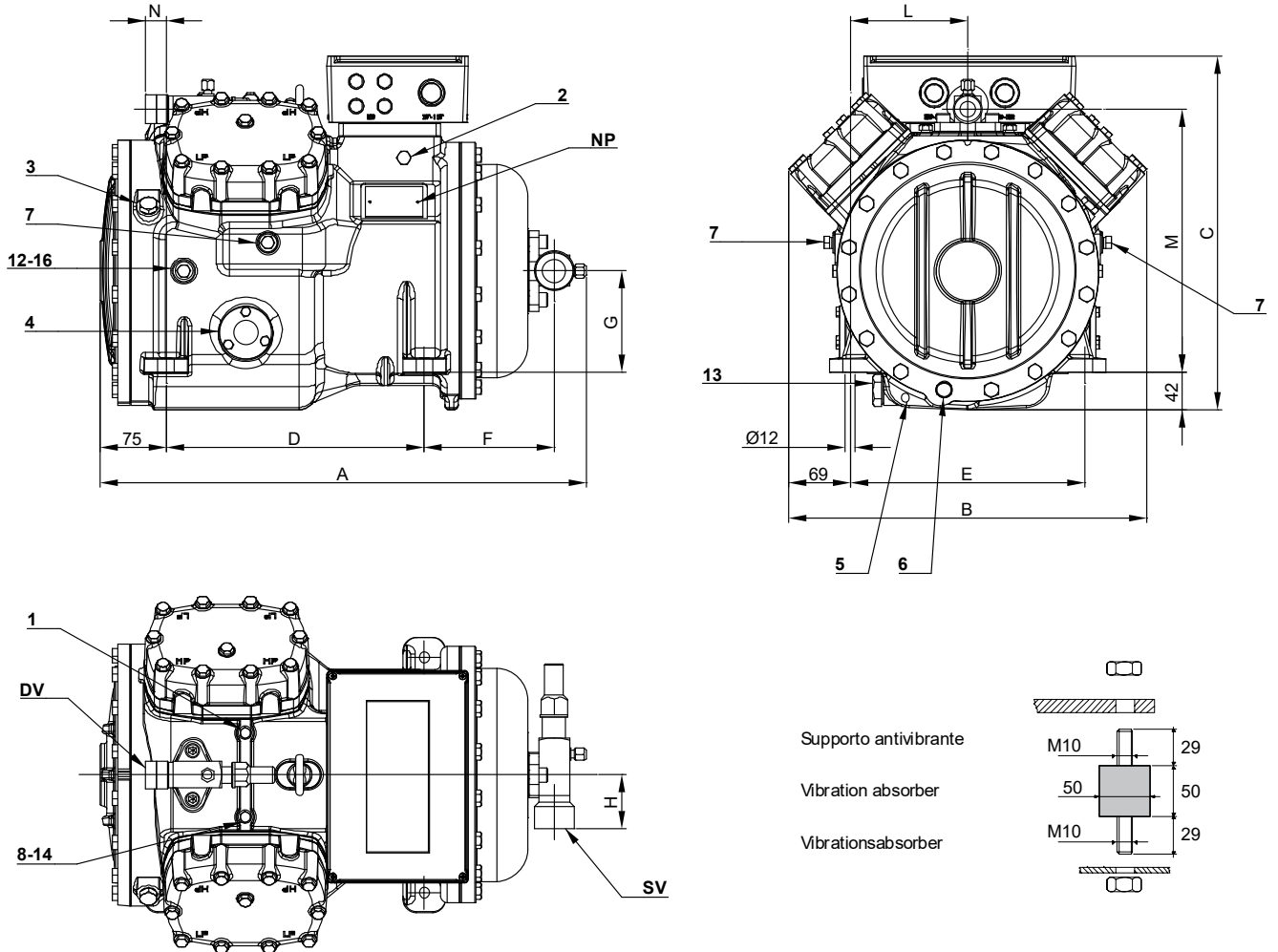

**Legend:**

SV: Suction Valve	1 3/8" in - 35 mm	1: High pressure connection	1/8" NPT
DV: Discharge valve	1 1/8" in - 28.575 mm	2: Low pressure connection	1/4" NPT
A: Length	550 mm	3: Oil charge plug	1/4" GAS
B: Width	405 mm	4: Oil level sight glass	-
C: Height	405 mm	5: Crankcase heater seat	-
D: Base mounting	292 mm	6: Oil drain plug	M10 x 30
E: Base mounting	266 mm	7: Liquid injection plug	1/4" NPT
F: Suction Valve	147 mm	8: Liquid injection sensor plug	1/8" NPT
G: Suction Valve	115 mm	12: Oil return plug	1/4" NPT
H: Suction Valve	58 mm	13: Magnetic plug	1/2" GAS
L: Discharge valve	133 mm	14: Max discharge temperature sensor connection	1/8" NPT
M: Discharge valve	298 mm	16: Crankcase pressure plug	1/4" NPT
N: Discharge valve	23 mm	NP: Nameplate	

All data subject to change without notice

**Model: S10-52Y**

Refrigerant: R449A

Power supply: 400/3/50 PWS

**Polynomial coefficients according to EN12900 for S10-52Y:**

\*S = T<sub>evap</sub> ; D = T<sub>cond</sub>

Reference conditions

Refrigerant	R449A
Ambient temperature	35 °C
Suction gas temperature	20 °C
Liquid subcooling	0 K
Frequency	50 Hz

	Refrigerating capacity [W]	Power input [W]
<b>C1</b>	6.529160E+004	1.740630E+003
<b>C2</b>	2.445830E+003	-2.240430E+002
<b>C3</b>	-5.811780E+002	3.066720E+002
<b>C4</b>	3.203010E+001	-6.678100E+000
<b>C5</b>	-1.863440E+001	8.929100E+000
<b>C6</b>	-1.183580E+000	-2.226390E+000
<b>C7</b>	1.429370E-001	-5.100030E-002
<b>C8</b>	-1.854810E-001	5.521640E-002
<b>C9</b>	-1.559340E-002	-1.934400E-002
<b>C10</b>	7.252820E-003	5.493770E-003

$$Y = C1 + C2*S + C3*D + C4*S^2 + C5*S*D + C6*D^2 + C7*S^3 + C8*D*S^2 + C9*S*D^2 + C10*D^3$$