

Input data

Refrigerant	R449A	
Reference temperature	Dew point temperature	
Calculation mode	Refrigeration / Air Cond.	
Operating mode	Subcritical	
Power supply	400/3/50	
Condensing temperature	°C	45
Condensing pressure	bar	18.86
Liquid subcooling	K	2
Liquid temperature	°C	38.72
Evaporating temperature	°C	-5
Evaporating pressure	bar	4.33
Suction gas temperature	°C	20
Evaporator superheating	K	5

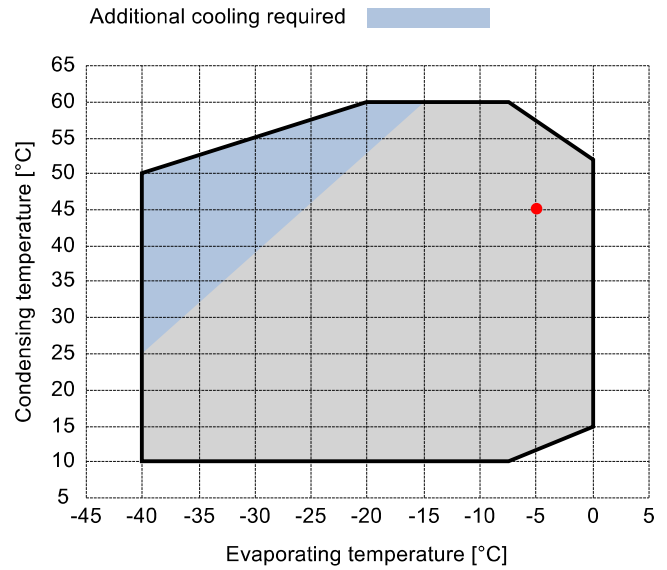

Output data

Compressor :	S15-56Y	
Number of compressors :	FSx1	
Refrigerating capacity	kW	34.732
Refrigerating capacity [*ref]	kW	34.004
Evaporator capacity	kW	30.762
Power input	W	12204
Condenser capacity, theor.	kW	46.936
Current	A	23.83
COP/EER	W/W	2.52
Mass flow	kg/h	778
Operating frequency	Hz	50
Connection	-	PWS
Operating mode	-	100%
Discharge temperature	°C	96.19
Ratio (%)	%	100.0%
Note	-	
Oil flow	l/min	-
Heat Exchanged (oil Cooler)	kW	-
Oil Temp. at Oil Cooler Outlet	°C	-
Certified by	-	Frascold

Certified by:

- Frascold tentative data

Legend:

- *ref: At conditions according to EN12900
- Suction gas temperature = 20 °C
- Liquid subcooling = 0 K

P&I Diagram:

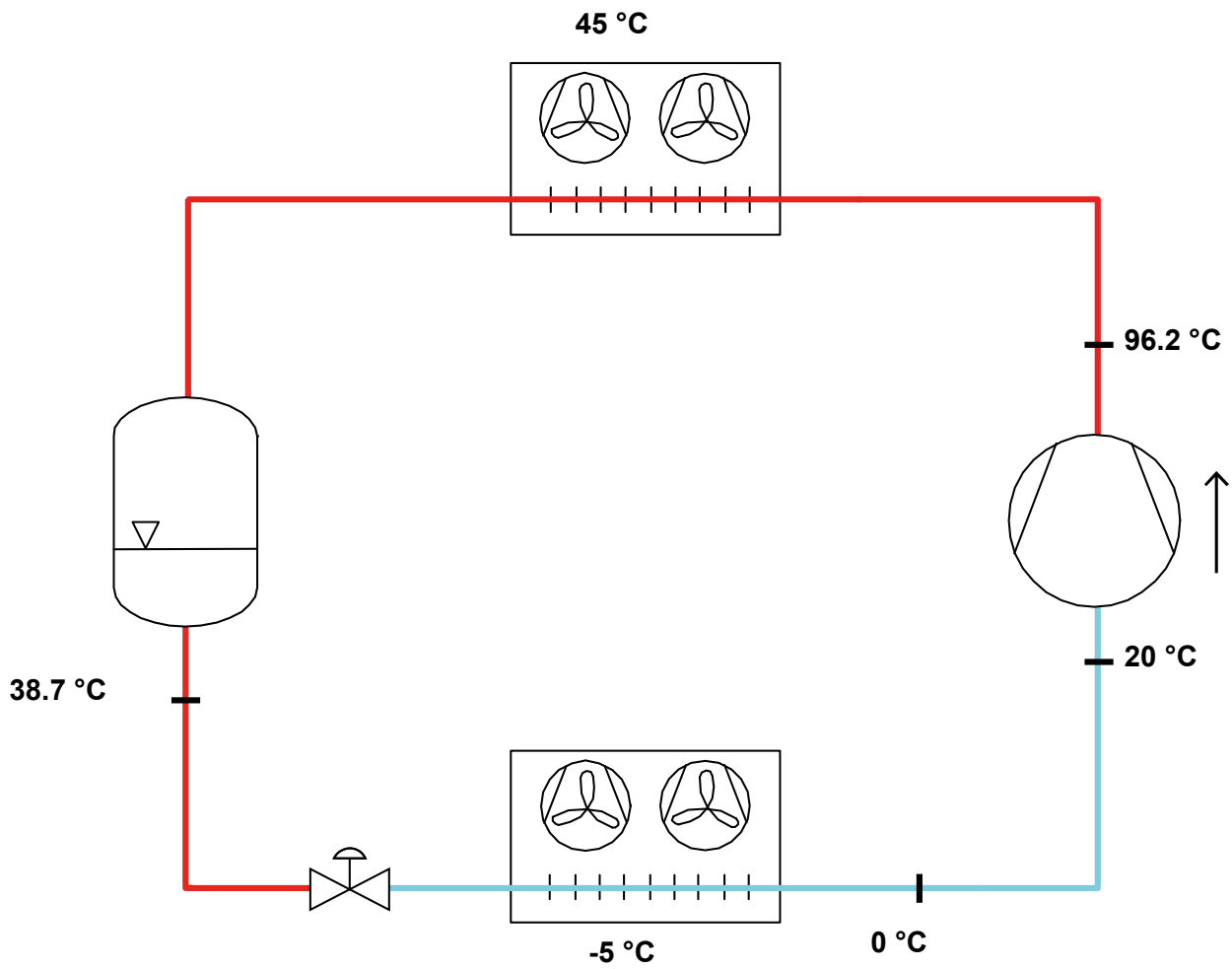

All data subject to change without notice

Model: S15-56Y

Refrigerant: R449A

Power supply: 400/3/50 PWS

Technical data:

Displacement	56 m³/h
Nominal compressor speed	1450 rpm
Motor voltage	400 V
Nominal operating frequency	50 Hz
Maximum allowed operating current (MRA)	30.7 A
Locked rotor current (LRA)	74.8 A
Locked rotor current (LRA), DOL	117.1 A
Number of pistons	4
Net weight	130 kg
Lubricant	FRASCOLD POE32
Oil charge	2.9 l
Maximum static pressure LP	20.5 bar
Maximum operating pressure HP	30 bar

Sound level:

Sound power level -10/45°C R404A @50Hz	78.5 dB(A)
Sound pressure (*) - Distance: 1 m	70.5 dB(A)
Sound power level -35/40°C R404A @50Hz	83 dB(A)
Sound pressure (*) - Distance: 1 m	75 dB(A)

*half sphere model

Motor connections:

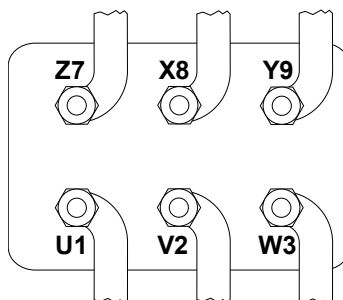

All data subject to change without notice

Model: S15-56Y

Refrigerant: R449A

Power supply: 400/3/50 PWS

Dimensions:

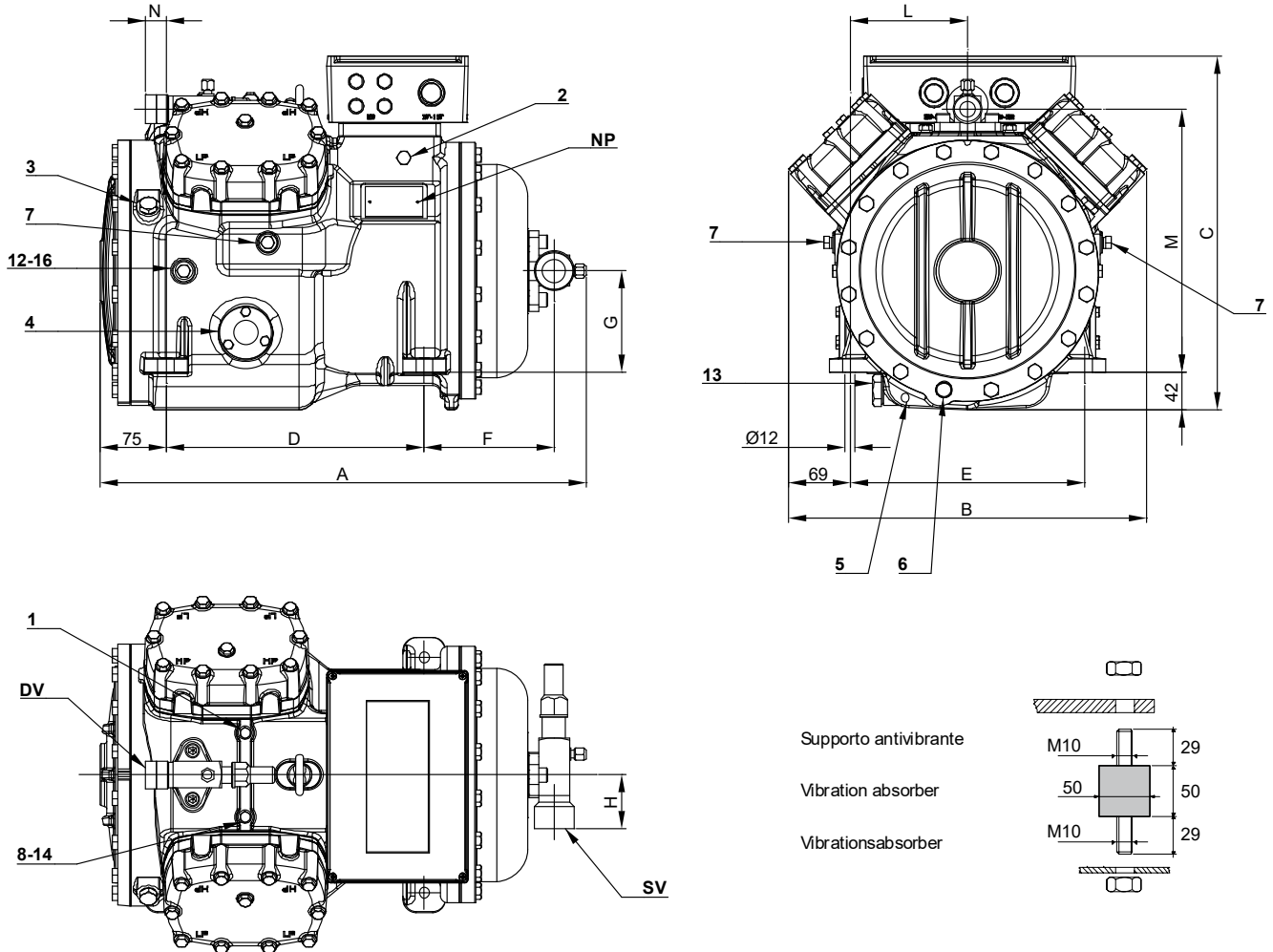

Legend:

SV: Suction Valve	1 5/8" in - 42 mm	1: High pressure connection	1/8" NPT
DV: Discharge valve	1 1/8" in - 28.575 mm	2: Low pressure connection	1/4" NPT
A: Length	550 mm	3: Oil charge plug	1/4" GAS
B: Width	405 mm	4: Oil level sight glass	-
C: Height	405 mm	5: Crankcase heater seat	-
D: Base mounting	292 mm	6: Oil drain plug	M10 x 30
E: Base mounting	266 mm	7: Liquid injection plug	1/4" NPT
F: Suction Valve	147 mm	8: Liquid injection sensor plug	1/8" NPT
G: Suction Valve	115 mm	12: Oil return plug	1/4" NPT
H: Suction Valve	61 mm	13: Magnetic plug	1/2" GAS
L: Discharge valve	133 mm	14: Max discharge temperature sensor connection	1/8" NPT
M: Discharge valve	298 mm	16: Crankcase pressure plug	1/4" NPT
N: Discharge valve	23 mm	NP: Nameplate	

All data subject to change without notice

Model: S15-56Y

Refrigerant: R449A

Power supply: 400/3/50 PWS

Polynomial coefficients according to EN12900 for S15-56Y:

*S = T_{evap} ; D = T_{cond}

Reference conditions

Refrigerant	R449A
Ambient temperature	35 °C
Suction gas temperature	20 °C
Liquid subcooling	0 K
Frequency	50 Hz

	Refrigerating capacity [W]	Power input [W]
C1	6.962680E+004	2.494530E+003
C2	2.617220E+003	-2.051850E+002
C3	-5.098770E+002	2.885330E+002
C4	3.472600E+001	-5.674260E+000
C5	-1.785280E+001	8.909290E+000
C6	-2.935060E+000	-1.057600E+000
C7	1.562760E-001	-3.514790E-002
C8	-1.931620E-001	5.431790E-002
C9	-3.530020E-002	-9.643040E-003
C10	1.476610E-002	-1.921970E-003

$$Y = C1 + C2*S + C3*D + C4*S^2 + C5*S*D + C6*D^2 + C7*S^3 + C8*D*S^2 + C9*S*D^2 + C10*D^3$$