

Input data

Refrigerant	R449A	
Reference temperature	Dew point temperature	
Calculation mode	Refrigeration / Air Cond.	
Operating mode	Subcritical	
Power supply	400/3/50	
Condensing temperature	°C	45
Condensing pressure	bar	18.86
Liquid subcooling	K	2
Liquid temperature	°C	38.72
Evaporating temperature	°C	-5
Evaporating pressure	bar	4.33
Suction gas temperature	°C	20
Evaporator superheating	K	5

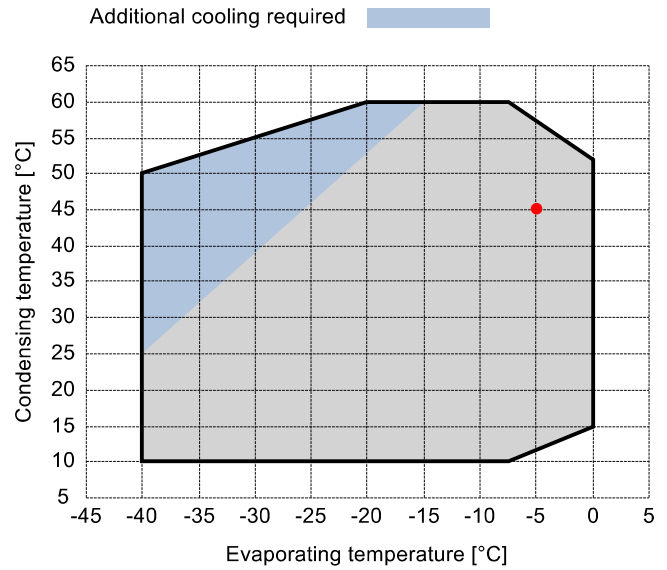

Output data

Compressor :	Q4-21.1Y	
Number of compressors :	FSx1	
Refrigerating capacity	kW	12.355
Refrigerating capacity [*ref]	kW	12.096
Evaporator capacity	kW	10.942
Power input	W	4778
Condenser capacity, theor.	kW	17.133
Current	A	8.56
COP/EER	W/W	2.29
Mass flow	kg/h	277
Operating frequency	Hz	50
Connection	-	DOL-STAR
Operating mode	-	100%
Discharge temperature	°C	101.31
Ratio (%)	%	100.0%
Note	-	
Oil flow	l/min	-
Heat Exchanged (oil Cooler)	kW	-
Oil Temp. at Oil Cooler Outlet	°C	-
Certified by	-	ASERCOM

Certified by:

- ASERCOM (ref. EN12900, 50 Hz, 100% cap.)



Legend:

- *ref: At conditions according to EN12900
- Suction gas temperature = 20 °C
- Liquid subcooling = 0 K

All data subject to change without notice

P&I Diagram:

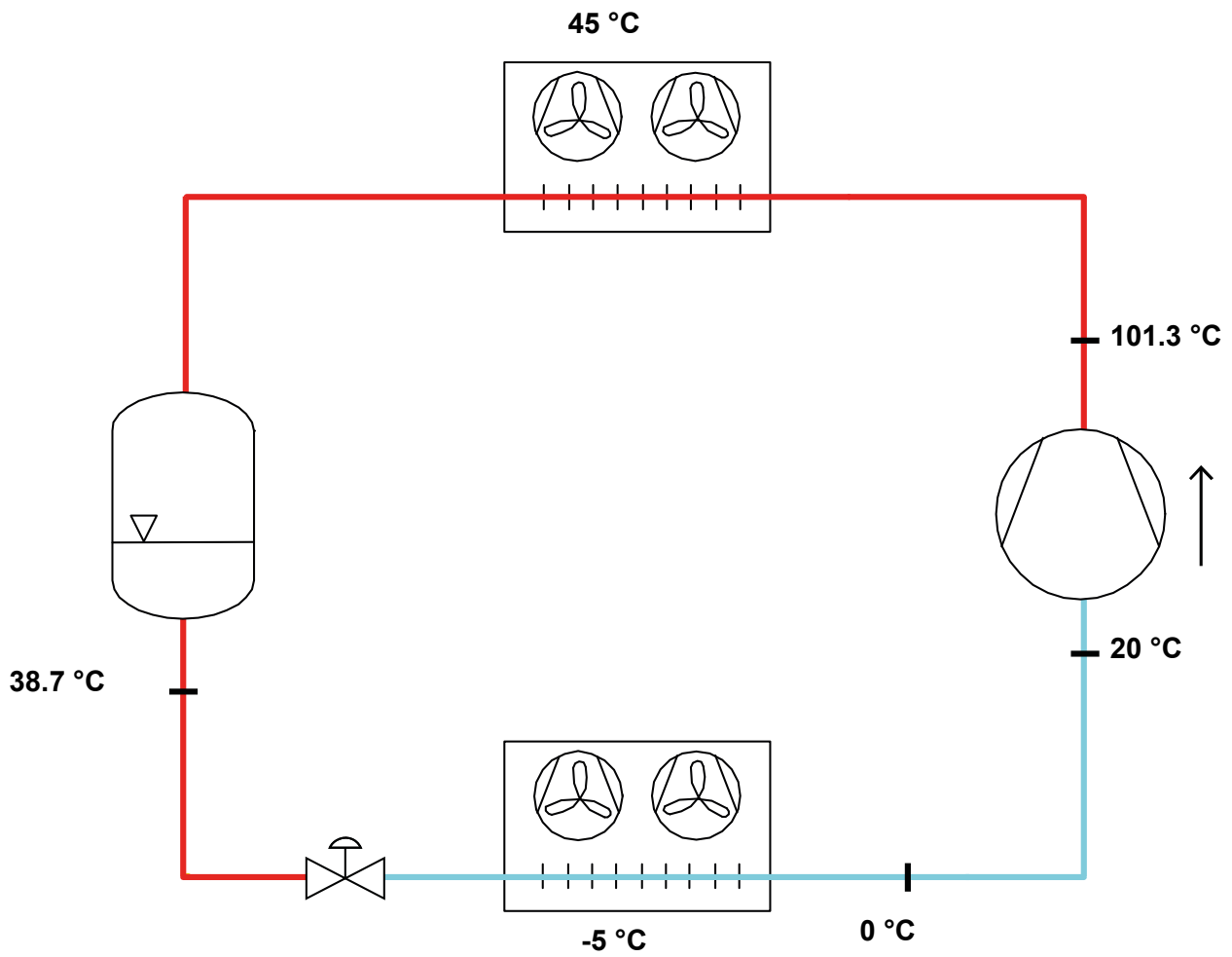

Model: Q4-21.1Y

Refrigerant: R449A

Power supply: 400/3/50 DOL-STAR

Technical data:

Displacement	21.18 m³/h
Nominal compressor speed	1450 rpm
Motor voltage	400 V
Nominal operating frequency	50 Hz
Maximum allowed operating current (MRA)	10 A
Locked rotor current (LRA)	53.2 A
Number of pistons	4
Net weight	79 kg
Lubricant	FRASCOLD POE32
Oil charge	1.6 l
Maximum static pressure LP	20.5 bar
Maximum operating pressure HP	30 bar

Sound level:

Sound power level -10/45°C R404A @50Hz	70 dB(A)
Sound pressure (*) - Distance: 1 m	62 dB(A)
Sound power level -35/40°C R404A @50Hz	72 dB(A)
Sound pressure (*) - Distance: 1 m	64 dB(A)

*half sphere model

Motor connections:

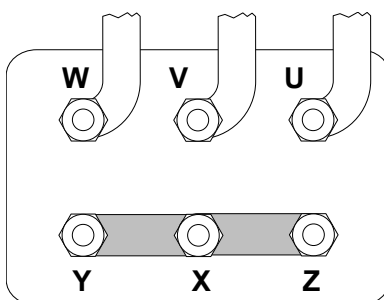

All data subject to change without notice

Model: Q4-21.1Y

Refrigerant: R449A

Power supply: 400/3/50 DOL-STAR

Dimensions:

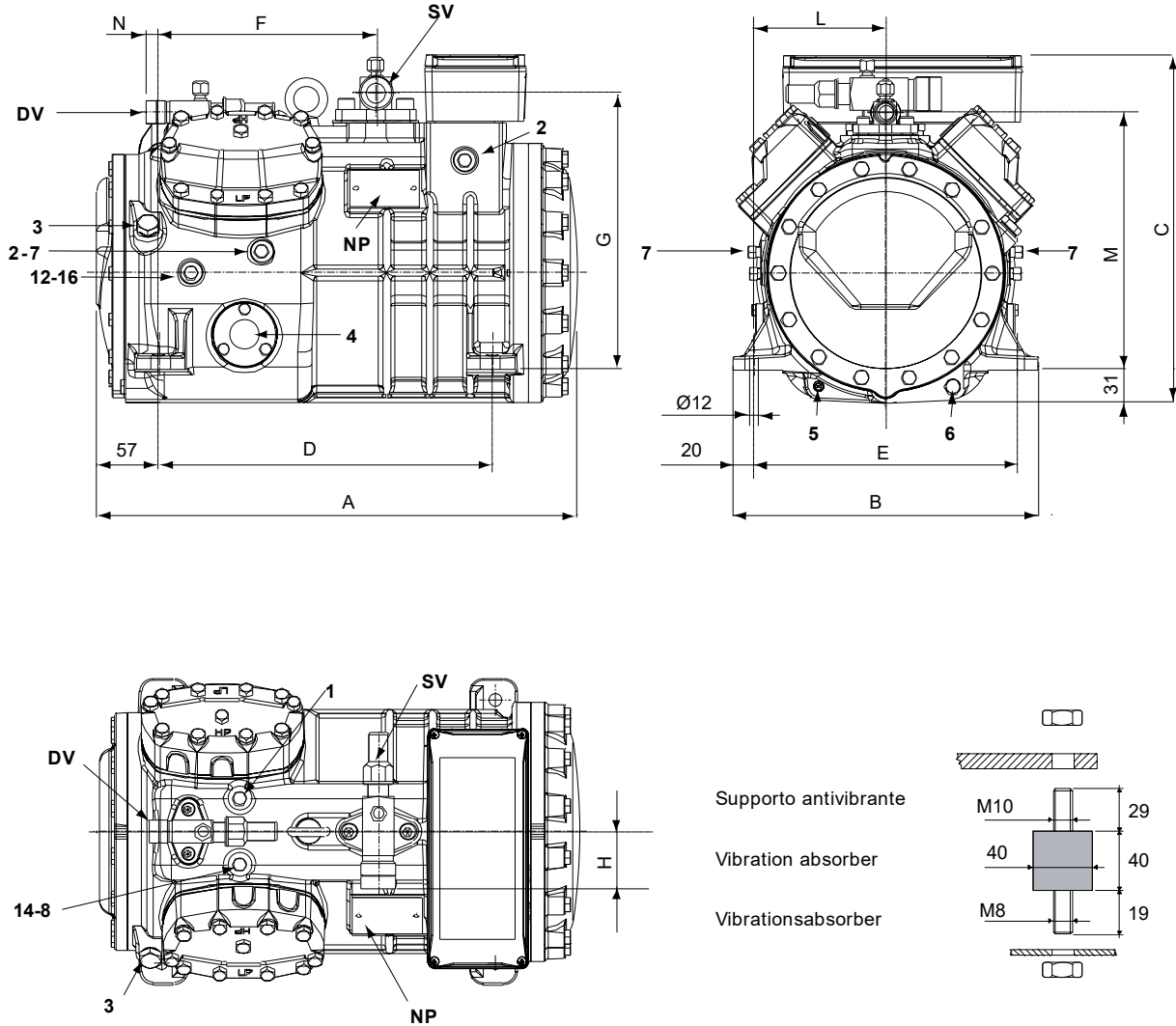

Legend:

SV: Suction Valve	1 1/8" in - 28.575 mm	1: High pressure connection	1/8" NPT
DV: Discharge valve	3/4" in - 19 mm	2: Low pressure connection	1/8" NPT
A: Length	449 mm	3: Oil charge plug	1/4" GAS
B: Width	286 mm	4: Oil level sight glass	-
C: Height	325 mm	5: Crankcase heater seat	-
D: Base mounting	312 mm	6: Oil drain plug	M8 x 22
E: Base mounting	246 mm	7: Liquid injection plug	1/8" NPT
F: Suction Valve	203 mm	8: Liquid injection sensor plug	1/8" NPT
G: Suction Valve	258 mm	12: Oil return plug	1/8" NPT
H: Suction Valve	53 mm	14: Max discharge temperature sensor connection	1/8" NPT
L: Discharge valve	123 mm	16: Crankcase pressure plug	1/8" NPT
M: Discharge valve	239 mm	NP: Nameplate	
N: Discharge valve	12 mm		

All data subject to change without notice

Model: Q4-21.1Y

Refrigerant: R449A

Power supply: 400/3/50 DOL-STAR

Polynomial coefficients according to EN12900 for Q4-21.1Y:

*S = T_{evap} ; D = T_{cond}

Reference conditions

Refrigerant	R449A
Ambient temperature	35 °C
Suction gas temperature	20 °C
Liquid subcooling	0 K
Frequency	50 Hz

	Refrigerating capacity [W]	Power input [W]
C1	2.811180E+004	1.767406E+003
C2	1.094060E+003	-3.511732E+001
C3	-3.655420E+002	7.272446E+001
C4	1.475950E+001	-1.474240E+000
C5	-1.318240E+001	2.002892E+000
C6	2.040180E+000	2.308460E-001
C7	6.121640E-002	-9.019078E-003
C8	-1.440250E-001	1.341201E-002
C9	3.418650E-002	7.034421E-003
C10	-1.148990E-002	-3.976381E-003

$$Y = C1 + C2*S + C3*D + C4*S^2 + C5*S*D + C6*D^2 + C7*S^3 + C8*D*S^2 + C9*S*D^2 + C10*D^3$$