

## Input data

Refrigerant	R449A	
Reference temperature	Dew point temperature	
Calculation mode	Refrigeration / Air Cond.	
Operating mode	Subcritical	
Power supply	400/3/50	
Condensing temperature	°C	45
Condensing pressure	bar	18.86
Liquid subcooling	K	2
Liquid temperature	°C	38.72
Evaporating temperature	°C	-5
Evaporating pressure	bar	4.33
Suction gas temperature	°C	20
Evaporator superheating	K	5

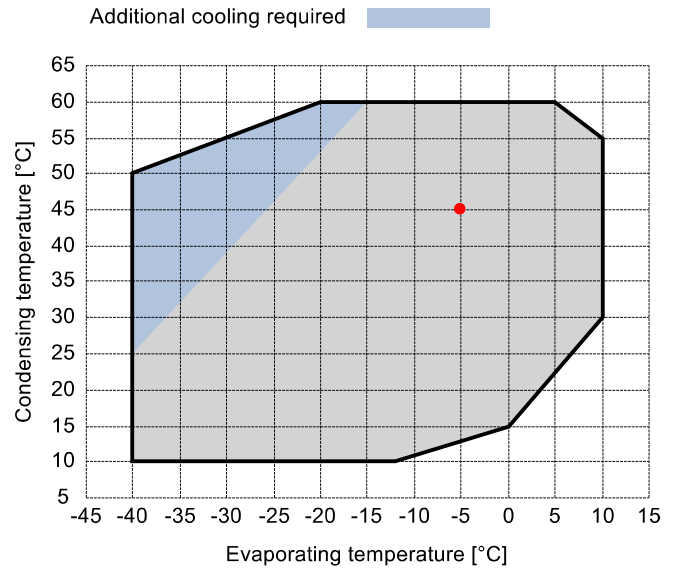

## Output data

<b>Compressor :</b>	<b>Q5-21.1Y</b>	
Number of compressors :	FSx1	
Refrigerating capacity	kW	12.912
Refrigerating capacity [ *ref ]	kW	12.641
Evaporator capacity	kW	11.436
Power input	W	4741
Condenser capacity, theor.	kW	17.653
Current	A	8.65
COP/EER	W/W	2.41
Mass flow	kg/h	289
Operating frequency	Hz	50
Connection	-	DOL-STAR
Operating mode	-	100%
Discharge temperature	°C	98.47
Ratio (%)	%	100.0%
Note	-	
Oil flow	l/min	-
Heat Exchanged (oil Cooler)	kW	-
Oil Temp. at Oil Cooler Outlet	°C	-
Certified by	-	Frascold

### Certified by:

- Frascold tentative data

### Legend:

- \*ref: At conditions according to EN12900
- Suction gas temperature = 20 °C
- Liquid subcooling = 0 K

**P&I Diagram:**

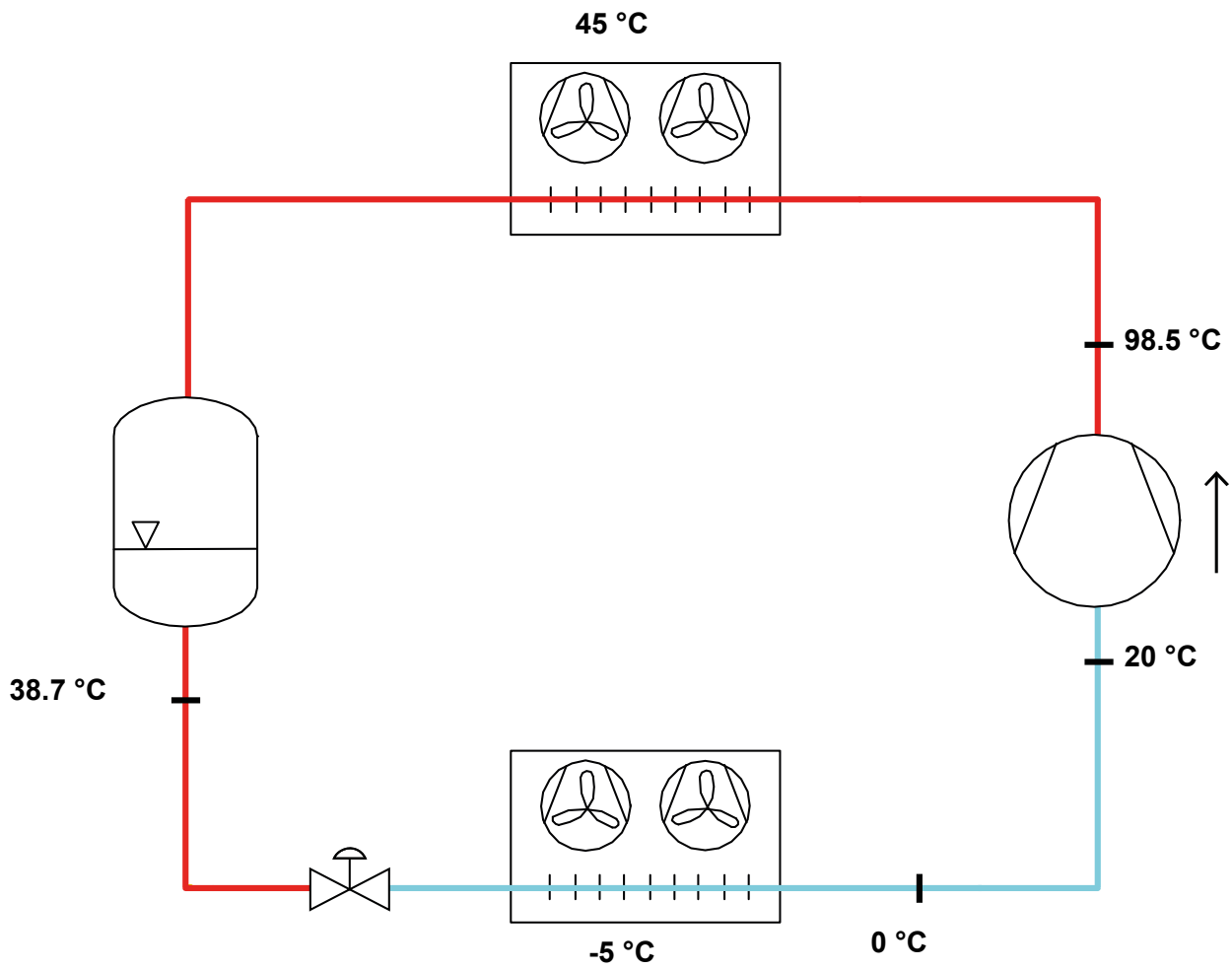

**Model: Q5-21.1Y**

Refrigerant: R449A

Power supply: 400/3/50 DOL-STAR

**Technical data:**

Displacement	21.18 m³/h
Nominal compressor speed	1450 rpm
Motor voltage	400 V
Nominal operating frequency	50 Hz
Maximum allowed operating current (MRA)	11.6 A
Locked rotor current (LRA)	63.1 A
Number of pistons	4
Net weight	79 kg
Lubricant	FRASCOLD POE32
Oil charge	1.6 l
Maximum static pressure LP	20.5 bar
Maximum operating pressure HP	30 bar

**Sound level:**

Sound power level 5/50°C R404A @50Hz	68.5 dB(A)
Sound pressure (*) - Distance: 1 m	60.5 dB(A)
Sound power level -10/45°C R404A @50Hz	70 dB(A)
Sound pressure (*) - Distance: 1 m	62 dB(A)

\*half sphere model

**Motor connections:**

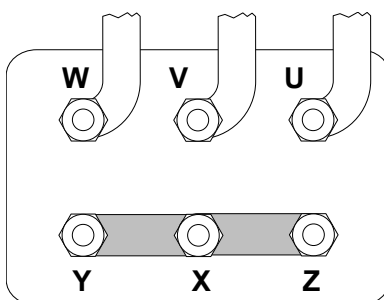

*All data subject to change without notice*

**Model: Q5-21.1Y**

Refrigerant: R449A

Power supply: 400/3/50 DOL-STAR

**Dimensions:**

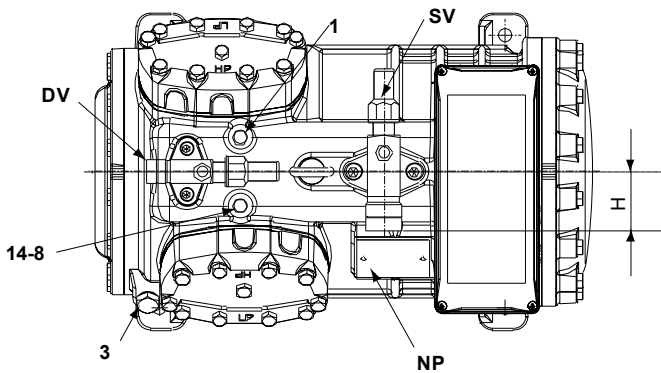
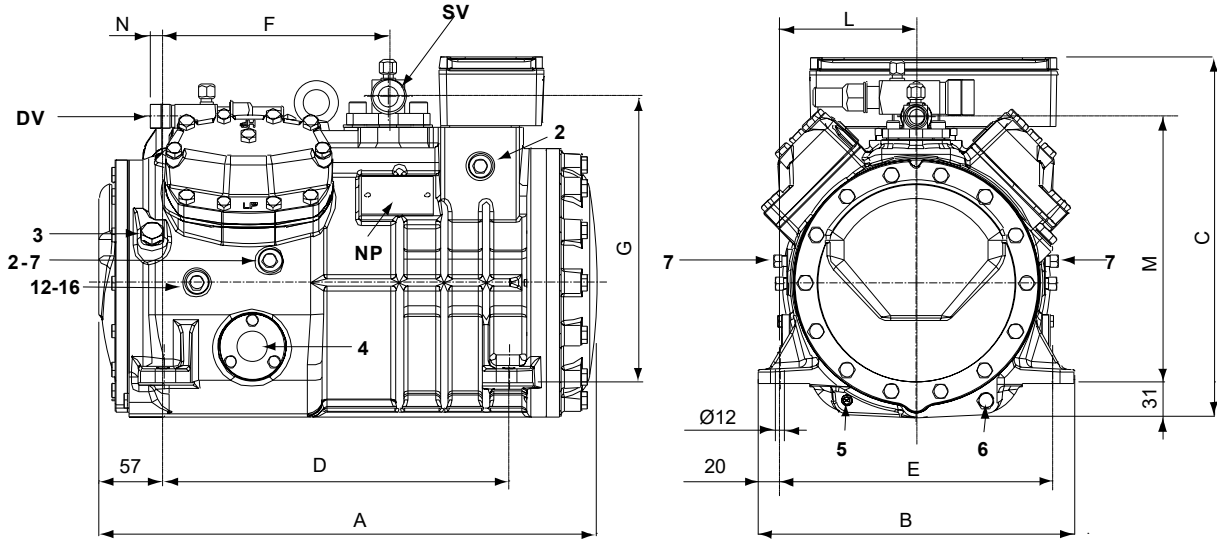

Supporto antivibrante

Vibration absorber

Vibrationsabsorber

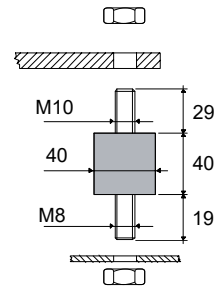

**Legend:**

SV: Suction Valve	1 1/8" in - 28.575 mm	1: High pressure connection	1/8" NPT
DV: Discharge valve	3/4" in - 19 mm	2: Low pressure connection	1/8" NPT
A: Length	449 mm	3: Oil charge plug	1/4" GAS
B: Width	286 mm	4: Oil level sight glass	-
C: Height	325 mm	5: Crankcase heater seat	-
D: Base mounting	312 mm	6: Oil drain plug	M8 x 22
E: Base mounting	246 mm	7: Liquid injection plug	1/8" NPT
F: Suction Valve	203 mm	8: Liquid injection sensor plug	1/8" NPT
G: Suction Valve	258 mm	12: Oil return plug	1/8" NPT
H: Suction Valve	53 mm	14: Max discharge temperature sensor connection	1/8" NPT
L: Discharge valve	123 mm	16: Crankcase pressure plug	1/8" NPT
M: Discharge valve	239 mm	NP: Nameplate	
N: Discharge valve	12 mm		

All data subject to change without notice

**Model: Q5-21.1Y**

Refrigerant: R449A

Power supply: 400/3/50 DOL-STAR

**Polynomial coefficients according to EN12900 for Q5-21.1Y:**

\*S = T<sub>evap</sub> ; D = T<sub>cond</sub>

Reference conditions	
Refrigerant	R449A
Ambient temperature	35 °C
Suction gas temperature	20 °C
Liquid subcooling	0 K
Frequency	50 Hz

	Refrigerating capacity [W]	Power input [W]
<b>C1</b>	2.686960E+004	1.660860E+003
<b>C2</b>	1.008110E+003	-6.399840E+001
<b>C3</b>	-2.303420E+002	6.685400E+001
<b>C4</b>	1.382180E+001	-1.893740E+000
<b>C5</b>	-7.960020E+000	3.170670E+000
<b>C6</b>	-8.076630E-001	6.518540E-001
<b>C7</b>	7.375750E-002	-1.245580E-002
<b>C8</b>	-7.696850E-002	2.030580E-002
<b>C9</b>	-1.456690E-003	-5.085130E-003
<b>C10</b>	8.315060E-003	-9.692720E-003

$$Y = C1 + C2*S + C3*D + C4*S^2 + C5*S*D + C6*D^2 + C7*S^3 + C8*D*S^2 + C9*S*D^2 + C10*D^3$$