



YORK® AMICHI™ SERIES AIR-COOLED DC INVERTER SCROLL CHILLERS AND HEAT PUMPS

Efficiency-optimized Heating and Cooling for Best-in-class Performance





EC Fans



Brazed Plate Heat Exchanger

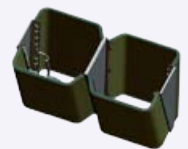

Condenser Coils



Optiview™ LT Controller
(Verasys™ Compatible)



Suction Accumulator

DC Inverter Scroll

Fixed-speed Scrolls

Exceeding Efficiency Standards

The YORK® Amichi™ Series Air-cooled DC Inverter Scroll Chiller and Heat Pump have been designed to meet tomorrow's efficiency standards today. Delivering performance beyond typical chiller and heat pump efficiency levels, the YORK® Amichi™ Series meets or exceeds stringent regulatory requirements (see chart, below) through an optimized combination of YORK® efficiency-enhancing technologies.

- **Direct current (DC) inverter technology** provides variable capacity control and allows Amichi™ Series chiller compressors to operate more efficiently across all cooling-load and ambient temperature conditions versus constant-speed chillers that use a step unloading design.
- **Electronically commutated (EC) fans** use more efficient motors and better aerodynamics to improve overall system efficiency and sound performance, particularly at part-load. At reduced ambient temperatures, the head pressure control varies fan speeds to optimize the system efficiency and ensure reliable operation. This combination of variable speed compressor and fans provides a displacement power factor as high as 0.93, lowering electricity costs.
- **High efficiency brazed plate heat exchanger** uses less refrigerant and transfers heat from the liquid to refrigerant more efficiently, providing excellent heat transfer performance in a compact size. This also results in a lower water side pressure drop, allowing the use of smaller pumps and further minimizing building power consumption.
- **Tandem compressor design** uses several circuits, which improves off-design and part-load efficiency by using the entire surface area of the heat exchanger at all conditions while also providing partial redundancy.

ECODESIGN REGULATIONS CATEGORY:	EFFICIENCY METRIC:	TOMORROW'S STANDARDS MET TODAY:
Comfort Heating	SCOP/ηsh	Amichi™ Heat Pump: Sept. 2017 Compliant (Tier 2)
Comfort Cooling	SEER/ηsc	Amichi™ Chiller: Jan. 2021 Compliant (Tier 2)
Process Cooling (Med. Temp.)	SEPR	Amichi™ Chiller: July 2018 Compliant (Tier 2)
Process Cooling (High Temp.)	SEPR	Amichi™ Chiller: Jan. 2021 Compliant (Tier 2)

Performance Without Compromise

The YORK® Amichi™ Series is a no-compromise solution for a variety of climates and locations. Built specifically to deliver better performance through a wider operating envelope, the Amichi™ chiller and heat pump can maintain efficiency in a variety of conditions without kits or add-ons – down to an impressive -18°C ambient in cooling mode and -15°C ambient in heating mode.

With the smallest footprint across the widest capacity range on the market, the YORK® Amichi™ Series is also the perfect solution for high performance in smaller spaces. Installation is simplified with a compact size that permits forklift loading, and a modular configuration allows units to be arranged in varying

footprints to fit different space requirements. This unique modularity means capacity can be increased incrementally as buildings are being constructed or spaces are becoming occupied. And if maintenance is required, other modules in the system will continue to operate, helping to reduce downtime and loss of capacity.

We want to ensure our neighbors are comfortable too, even in retrofits. That's why our systems offer two levels of sound performance. If requirements call for sound attenuation beyond our standard low-noise levels, an optional Ultra Quiet Kit can further reduce sound power by an impressive 6 dBA, providing one of the quietest units available.



Advanced Control Made Easy

Comfort, productivity and up to half of the energy used in your building – these are all factors affected by how your chiller operates and how it interacts with other components in your HVAC&R system. To help maximize efficiency and keep you in control, the YORK® Amichi™ Series comes standard with integrated Smart Equipment. This technology allows the equipment to connect seamlessly to building controls like our world-class *Verasys™* system, where smart-enabled equipment can self-identify and interoperate.

Verasys™ provides a truly plug-and-play experience, with no programming or commissioning tools required. Remote access over a secure internet connection and alarm notifications via email or text are possible through *Verasys™*. The user-friendly graphical interface provides easy access to critical equipment and facility information to help minimize the risk of unplanned downtime and costly repairs. *Verasys™* also provides enhanced energy efficiency control, allowing a facility owner to potentially

move from an average Class D efficiency classification to a Class A efficiency classification according to the EN 15232 standard. The key to this efficiency is demand control, where *Verasys™* routes the energy requirements of a room or space to the heating and cooling equipment – matching the demand-side and the supply-side to provide greater overall energy efficiency.

In addition to Smart Equipment capabilities, the YORK® Amichi™ Series provides added flexibility with standard BACnet MS/TP, Modbus RTU or N2 connectivity for communication with virtually any building management system. This advanced, embedded control capability also allows multiple chillers and/or heat pumps to be connected and monitored through a single controller. Each unit comes equipped with a touch-screen display featuring an easy-to-use, web-style interface and intuitive navigation for easy access to operational data. Information can be displayed in multiple languages, and setup is very easy.

PLUG & PLAY EXPERIENCE



A History of Reliability

When your reputation is at stake, count on efficient, reliable cooling and heating solutions from YORK® to lower costs and maximize uptime with dependability you can count-on. Our locally based stocking allows quick shipment to European locations. And with our units shipping as a complete package, everything arrives at the same time. We also offer a variety of standardized, locally stocked parts to ensure our systems continue to provide maximum uptime in every installation.

With the YORK® Amichi™ Series Air-cooled Scroll Chiller and Heat Pump, we're building on our legacy of cooling solutions and technology leadership. We don't judge success based on theoretical findings, but real-world experience. Our first-generation modular chiller was built over a decade ago. We use DC inverter technology proven in over three decades of use. Our use of inverter scroll technology dates to 1985. And every new YORK® chiller is subjected to a Highly Accelerated Life Test



(HALT) during the design product development stages, allowing us to simulate a variety of extreme conditions and ensuring long-term operational reliability and quality. But our pursuit of quality doesn't stop there.

- **Decades of extensive air-cooled expertise** is backed by proven components used in installations across the globe and in a variety of conditions.
- **Tandem compressor management** improves overall reliability by balancing system operation time between each compressor.
- **Smart logic controller** coordinates and optimizes units for off-design and part-load operation.
- **Intelligent defrost** optimizes the sequencing of the defrost cycle and allows the remaining modules in the system to continue to provide heat, reducing interruptions.
- **Compliance and certifications** include EcoDesign 2021 regulatory compliance, Eurovent certification and CE/PED certification.

The YORK® Amichi™ Series is a no-compromise solution that delivers industry-leading efficiency, unmatched flexibility, world-class sound performance, extensive control capability and long-lasting reliability. These highly optimized designs use advanced components and innovative thinking to provide the best-in-class performance only the world-leader in chiller solutions could deliver.



Base Model

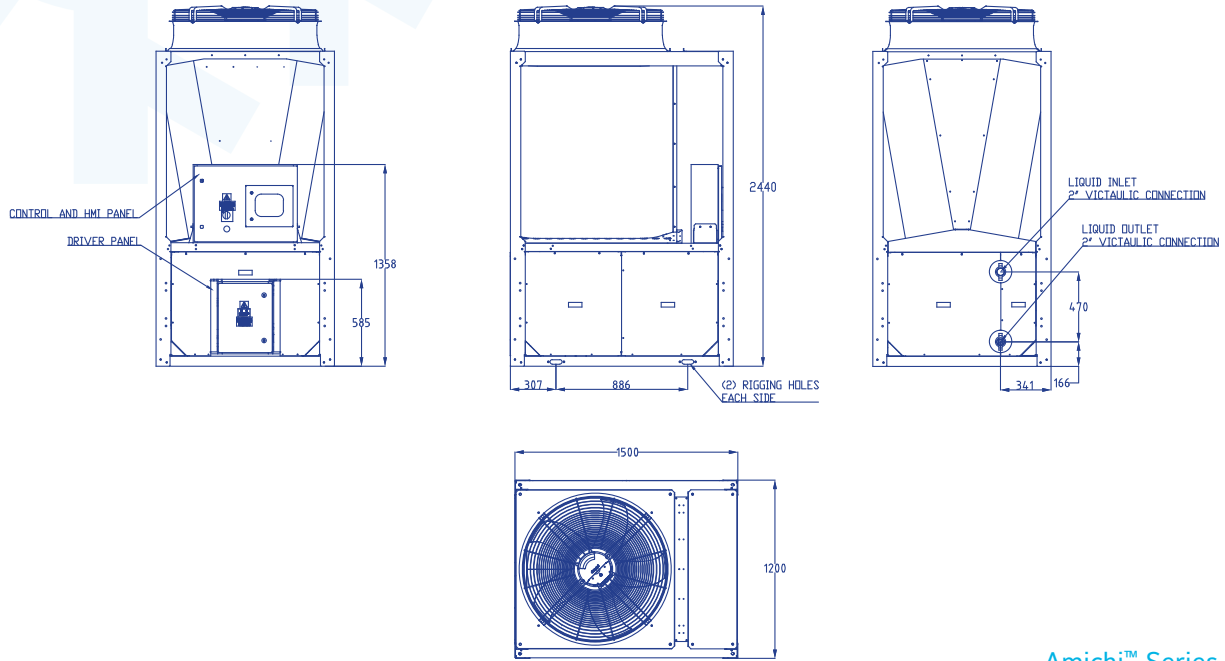

All dimensions in millimeters.

Amichi™ Series 0045, 0065

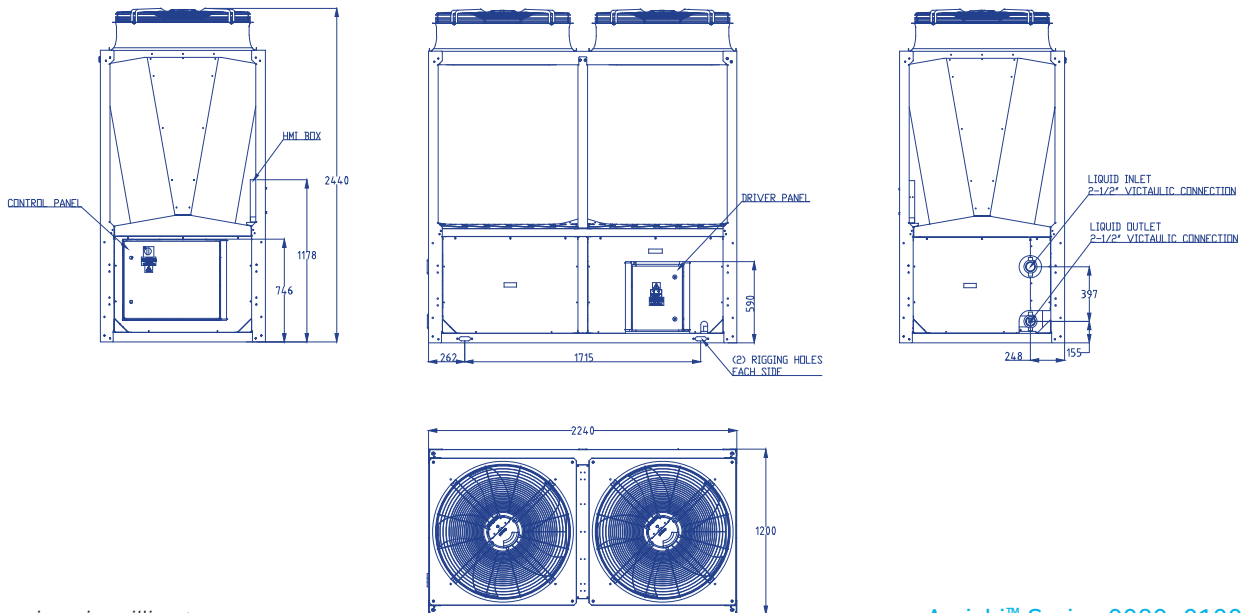

All dimensions in millimeters.

Amichi™ Series 0080, 0100, 0130

With Pump Kits

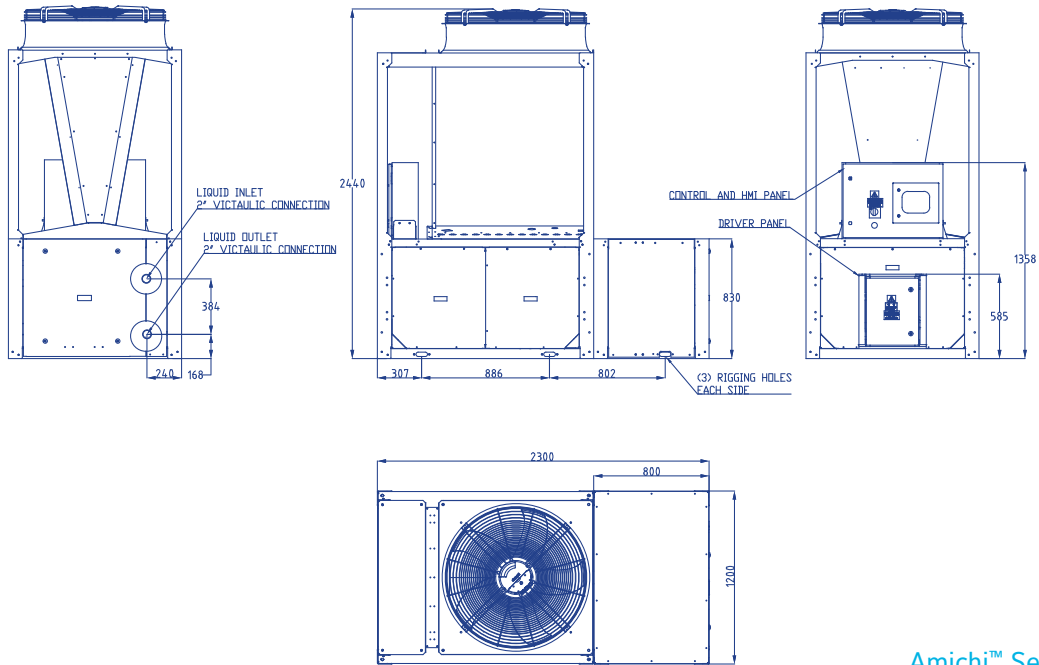

All dimensions in millimeters.

Amichi™ Series 0045, 0065

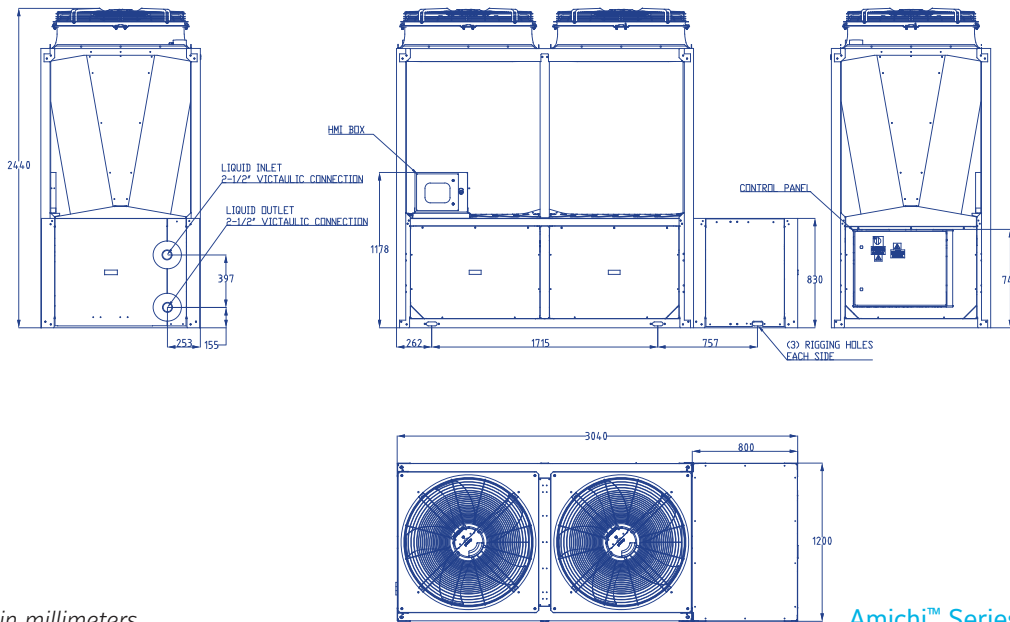

All dimensions in millimeters.

Amichi™ Series 0080, 0100, 0130

Model		Amichi™ Series Chiller and Heat Pump						
		0045	0065	0080	0100	0130		
Performance	Cooling capacity c/o units	kW	45	60	79	100	123	
	Cooling capacity h/p units	kW	45	60	79	100	123	
	Heating capacity h/p units	kW	50	61	88	96	130	
	COP		3.09	2.92	3.21	2.99	2.77	
	Energy Efficiency Ratio	EER	2.89	2.79	3.17	3.04	2.99	
	ESEER		4.97	4.70	4.78	4.66	4.67	
	Capacity steps		Stepless (inverter)					
Power input	Sound power level STD / LN	dB(A)	81/76	82/77	83/77	84/79	85/81	
	Cooling c/o units	kW	15.5	21.5	25.1	32.8	41.2	
	Cooling h/p units	kW	15.5	21.5	25.1	32.8	41.2	
Refrigerant	Heating h/p units	kW	17.9	21.5	28.9	34.7	47.1	
	Refrigerant circuits	#	1	1	2	2	2	
	Refrigerant (R410A) charge / circuit	kg		9.5	12.3	8.5	9.5	11.4
				-	-	9.05	11	11.4
				-	-	-	-	-
			-	-	-	-	-	
Compressor	Compressor type		DC scroll inverter + scroll					
	Quantity	#	2	2	3	3	4	
Air side heat exchanger	Fan motor type		EC motor					
	Fans quantity	#	1	1	2	2	2	
	Working ambient temp. cooling mode	°C	-18 ~ 48°C					
	Working ambient temp. heat. mode	°C	-15 ~ 25°C					
Water side heat exchanger	Type		Plate heat exchanger					
	Unit water volume (w/o pump kit)	l	7	10	14	16	16	
	Nominal water flow	l/s	2.2	2.9	3.8	4.8	5.9	
	Pressure drop	kPa	25.7	24.2	24.6	30.8	38.2	
	Working range water leaving temp. cooling	°C	-8 ~ 20°C					
	Working range water leaving temp. heating	°C	25 ~ 55°C					
Dimensions & weight	Water connections type		Victaulic					
	Height	mm	2440					
	Width	mm	1200					
	Depth	mm	1500		2250			
	Operating weight c/o units	kg	575	598	875	901	979	
	Operating weight h/p units	kg	587	610	893	920	999	
Electrical features	Voltage / Phases / Frequency	V/ph/hz	400 / 3 / 50+N+E					

Chiller: Cooling only units models.

Heat Pump: Air to water heat pump models.

Nominal conditions: Cooling capacities in kW given for 7°C water leaving temperature Δt 5°C and 35°C ambient temperature.

Heating capacities in kW given for 45°C water leaving temperature and 7°C ambient temperature.

Ratings in accordance with EN14511:2013.





 **YORK**[®]
INSTALL CONFIDENCE.

Johnson Controls, the Johnson Controls logo, the Smart Equipment logo, YORK and Verasys are registered trademarks of Johnson Controls, Inc. in the United States of America and other countries. Other trademarks used herein may be trademarks or registered trademarks of other companies. ©2017 Johnson Controls, Inc. P.O. Box 423, Milwaukee, WI 53201. All rights reserved worldwide. Printed in USA PUBL-8740-A-1017.

FOR MORE INFORMATION VISIT JOHNSONCONTROLS.COM

