

# REX

## Power Flaring

# RF20N

### RF20N

### Operation Manual

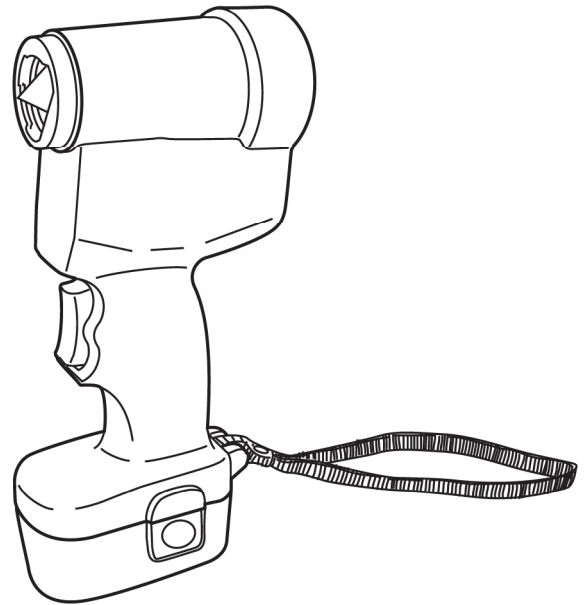
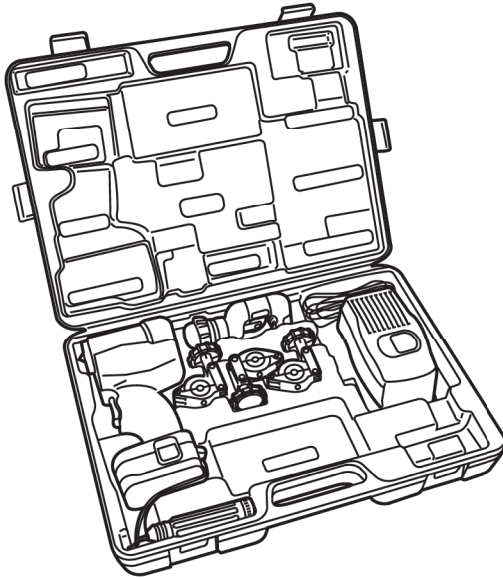

Be sure to read this  
Operation Manual before  
using the machine

-Note-

- Be sure to hand this operation manual to the user.
- Carefully read through this operation manual before using the machine, to ensure safe and effective use.
- Be sure to keep this operation manual where the operator can refer to it whenever necessary.

Date of purchase :

Year

Month

Sales agent :

- Be sure to observe the Safety Precautions described below to prevent accidents such as fire, electric shock and injury.
- Read these Safety Precautions carefully before using the machine, and operate the machine according to the instructions.
- Do not use the machine in any way other than as described in this operation manual.

## — Contents —

Safety Precautions .....	1
Names of Parts/Standard Specifications/Standard Accessories .....	5
Operating Instructions .....	7
Regular Maintenance and Inspection .....	12
Repairs .....	12
Before Asking for Repairs or Servicing .....	13
Special Accessories .....	14

---

Definitions of **▲ WARNING** and **▲ CAUTION**

In this operation manual, warnings are divided into **▲ WARNING** and **▲ CAUTION**.  
**▲ WARNING** : indicates actions which could possibly result in death or severe injury to the user if the machine is used incorrectly.

**▲ CAUTION** : indicates actions which could possibly result in injury to the user, or physical damage, if the machine is used incorrectly.

Even items described as **▲ CAUTION**, could have serious results under certain conditions.

Be sure to observe these warnings carefully as they greatly affect safety.

- If this operation manual is lost or damaged, promptly order a replacement from our agent or sales agent.
  - Parts and specifications are subject to change without prior notice, due to improvements in quality, performance or safety standards. In such cases, the contents, photographs, illustrations, etc. of this manual may be different to the product you have purchased.
-

# Safety Precautions



## WARNING

### General Safety Instructions

WARNING! Read all instructions very carefully. Failure to follow any instructions below may result in electric shock, fire and/or serious injury.

The term 'power tool' in all items below refers to your cordless, battery-operated power tool.

KEEP THESE INSTRUCTIONS SAFE.

#### 1) Work area

- a) Keep the work area tidy and well lit. Cluttered or badly lit areas invite accidents.
- b) Do not operate power tools in explosive atmospheres, such as in the presence of flammable liquids, gases or dust. Power tools create sparks which may ignite dust or fumes.
- c) Keep children and bystanders away while operating the tool. Distractions can cause you to lose control.
- d) Take care when working high up.
  - When working in elevated locations, make sure that there is nobody below you.

#### 2) Electrical safety

- a) Avoid body contact with earthed or grounded surfaces such as pipes, radiators, cookers and refrigerators. There is an increased risk of electric shock if your body is earthed or grounded.
- b) Do not expose power tools to the rain or wet conditions. If water gets inside a power tool, it will increase the risk of electric shock.
- c) Ensure you use the correct voltage.
  - Be sure to use the voltage indicated on the name plate or in the operation manual. If the voltage is different from the voltage indicated it could lead to overheating, smoke or fire.

#### 3) Personal safety

- a) Stay alert, watch what you are doing and use common sense when operating a power tool. Do not use a power tool when you are tired or under the influence of drugs, alcohol or medication. A momentary lack of attention while operating power tools could result in serious personal injury.
- b) Use safety equipment. Always protect your eyes. Safety equipment such as dust masks, non-skid safety shoes, hard hats, or hearing protection used in appropriate situations will reduce the risk of personal injury.
- c) Remove any adjusting keys or wrenches before turning the power tool on. A wrench or a key left attached to a rotating part of the tool may result in personal injury.
- d) Do not overreach. Keep a proper footing and balance at all times. This enables better control of the power tool if something unexpected happens.
- e) Dress appropriately. Do not wear loose clothing or jewellery. Keep your hair, clothing and gloves away from moving parts. Loose clothes, jewellery or long hair can get caught in moving parts.
- g) If devices are provided for connection to dust extraction and collection equipment, ensure these are connected and used properly. Use of such devices can reduce dust-related hazards.

#### 4) Power tool use and care

- a) Ensure the switch is in the OFF position before inserting the battery pack or there could be an accident.
- b) Recharge only with the charger specified by the manufacturer. A charger that is



## WARNING

suitable for one type of battery pack may carry the risk of fire when used with another battery pack.

- c) Use power tools only with specifically designated battery packs. Use of any other battery packs may result in injury or fire.
- d) When the battery pack is not in use, keep it away from other metal objects such as paper clips, coins, keys, nails, screws or other small metal objects that could make a connection between the terminals. Shorting the battery terminals may cause burns or a fire.
- e) If the battery is mistreated, it may exude an acidic liquid; avoid contact with such acid. If you touch it accidentally, wash with water immediately. If it gets in your eyes, seek medical help immediately. Acid from the battery may also cause burns or irritation.
- f) Do not use the power tool with excessive force. Use the correct power tool for your application. The correct power tool will do the job better and safer at the rate for which it was designed.
- g) Do not use the power tool if the switch does not work properly. Any power tool that cannot be controlled with the switch is dangerous and should be repaired.
- h) Remove the battery pack from the power source before making any adjustments, changing accessories, or storing power tools. Such preventive safety measures reduce the risk of starting the power tool accidentally.
- i) Store idle power tools out of the reach of children and do not allow people unfamiliar with either the tool or these instructions to operate it. Power tools can be dangerous in the hands of untrained users.
- j) Perform maintenance regularly. Check for misalignment or binding of moving parts, breakages or any other condition that may affect the tool's operation. If damaged, have the tool repaired before use. Many accidents are caused simply by poor maintenance.
- k) Keep cutting tools sharp and clean. Properly maintained cutting tools with sharp cutting edges are less likely to bind and are easier to control.
- l) Use the power tool, accessories and tool bits etc., in accordance with these instructions and in the manner intended for the particular type of power tool, taking into account the working conditions and the work to be performed. Use of the power tool for any purpose other than that intended could result in a hazardous situation.
- m) Use only designated accessories and attachments.
  - Using accessories and attachments other than those designated in the operation manual or REX catalogues can lead to accidents or injury.
  - If any abnormality is noticed, stop operation immediately.
- n) If the machine does not function smoothly, or abnormalities such as unusual odours, vibration or noise are detected, stop the machine immediately.
  - Check symptoms against the items in 'Troubleshooting' at the end of this manual, and follow the corresponding instructions. Using the machine continuously can lead to overheating, smoke or fire, resulting in accidents or injury.
- o) Hold the tool securely.
  - When the tool is switched on and the flare cone starts rotating, the hand you hold the tool with may be jarred; take care not to hit any objects around you.

### 5) Battery use and care

- a) Ensure the switch is in the OFF position before inserting the battery pack or there could be an accident.
- b) Recharge only with the charger specified by the manufacturer. A charger that is

# Safety Precautions



## WARNING

- suitable for one type of battery pack may carry the risk of fire when used with another battery pack.
- c) Use power tools only with specifically designated battery packs. Use of any other battery packs may result in injury or fire.
  - d) When the battery pack is not in use, keep it away from other metal objects such as paper clips, coins, keys, nails, screws or other small metal objects that could make a connection between the terminals. Shorting the battery terminals may cause burns or a fire.
  - e) If the battery is mistreated, it may exude an acidic liquid; avoid contact with such acid. If you touch it accidentally, wash with water immediately. If it gets in your eyes, seek medical help immediately. Acid from the battery may also cause burns or irritation.
  - f) Never use boosters or other transformers for charging
    - This can damage the charger; always use with a 220-240V supply.
  - g) Never charge with an engine generator or DC power source.
    - Do not use an engine generator or DC power source for charging or the charger may be damaged.
  - h) Always charge indoors.
    - When charging, do not let the battery or charger get wet; charge indoors.
    - Do not place the charger close to an open flame.
    - Keep all inflammable materials away from the charger.
    - The battery or charger may get slightly hot while charging; choose a dry and well-ventilated place that is not exposed to direct sunlight.
  - i) Moisture can cause accidents.
    - Do not try to charge or use the product in the rain or in wet or damp places. Moisture can cause electric shock, in addition to weakening the insulation of the charger or motor. Always avoid moisture.
  - j) Unplug the charger once charging is complete.
    - Unplug the charger cord from the power source after charging is finished. If there is a power failure, always remove the charger attachment plug from the power source.
  - k) Charge within a range of 5° C to 40° C.
    - The product employs a special charging circuit for fast charging (about 1 hour). Always charge within a temperature range of 5° C to 40° C. Below 5° C, it may overcharge, shortening the life of the charger. Above 40° C, charging may not be possible. The most suitable range is 20° C to 25° C.
  - l) Do not charge continuously with the same charger
    - If the same charger is used to charge a number of tools continuously, it could be damaged due to overheating. Once charging is finished, allow the charger to cool down for about 15 minutes before using it again.
    - Normally, at an ambient temperature of about 20° C, the tool will be fully charged in about 1 hour and the pilot lamp will then go out. However, below 20° C, the pilot lamp may stay on even after an hour.
  - m) Do not immediately recharge a battery that has been used up quickly.
    - A battery that has been used up quickly due to continuous operation becomes abnormally hot. Therefore, when such a battery is placed in the charger, a red pilot lamp will light up, either preventing a recharge or resulting in an insufficient charge. Always allow the battery to cool before charging it.
  - n) Do not charge for more than 2 hours.
    - If the pilot lamp stays on even after charging for 2 hours, the product may be



## WARNING

faulty. Stop charging and take the product to your nearest sales agent.

- o) Keep the battery mounting hole clean.
  - The battery mounting hole on the charger has charging terminals. If this hole is contaminated with metal chips, water or other foreign matter, the terminals may be short-circuited, causing damage to the charger.
- p) Do not disassemble the battery of the charger.
  - The battery houses a special device designed for quick charging (about 1 hour); never try to disassemble it or it may be damaged.
  - Never try to disassemble the charger. It houses condensers and electric parts and disassembling it could result in electric shock or damage.
- q) Never put the battery in a fire.
  - Never put the battery in a fire or incinerator or it may explode.
- r) Keep the ventilation hole on the charger clean.
  - Keep the ventilation hole on the charger clear of metal chips and inflammable materials as they may cause electric shock or damage. Avoid using the charger in dusty places.
- s) Stop charging if any abnormality is detected.
  - If you detect abnormal heat or any other abnormality while charging, stop immediately and take the charger for repairs.
- t) Store the charger properly.
  - Store the charger in a dry place, out of the reach of children and where the temperature does not exceed 40°C. Never store under the eaves etc, where rain might get in. Deterioration of the electrical insulation can result in electric shock.

### 6) Servicing

- a) Have your power tool serviced by a qualified repair person using only identical replacement parts. This will ensure that the safety of the power tool is maintained.
- b) For overhaul and repair of the tool, ask an appointed REX agent.
  - Our products comply with corresponding safety standards. Do not remodel.
  - Be sure to ask your sales agent or our sales branch for any repairs. If repairs are carried out by unskilled or unqualified personnel, the performance of the unit will be adversely affected and may result in accident or injury.

# Names of Parts/Standard Specifications/Standard Accessories

## Names of Parts

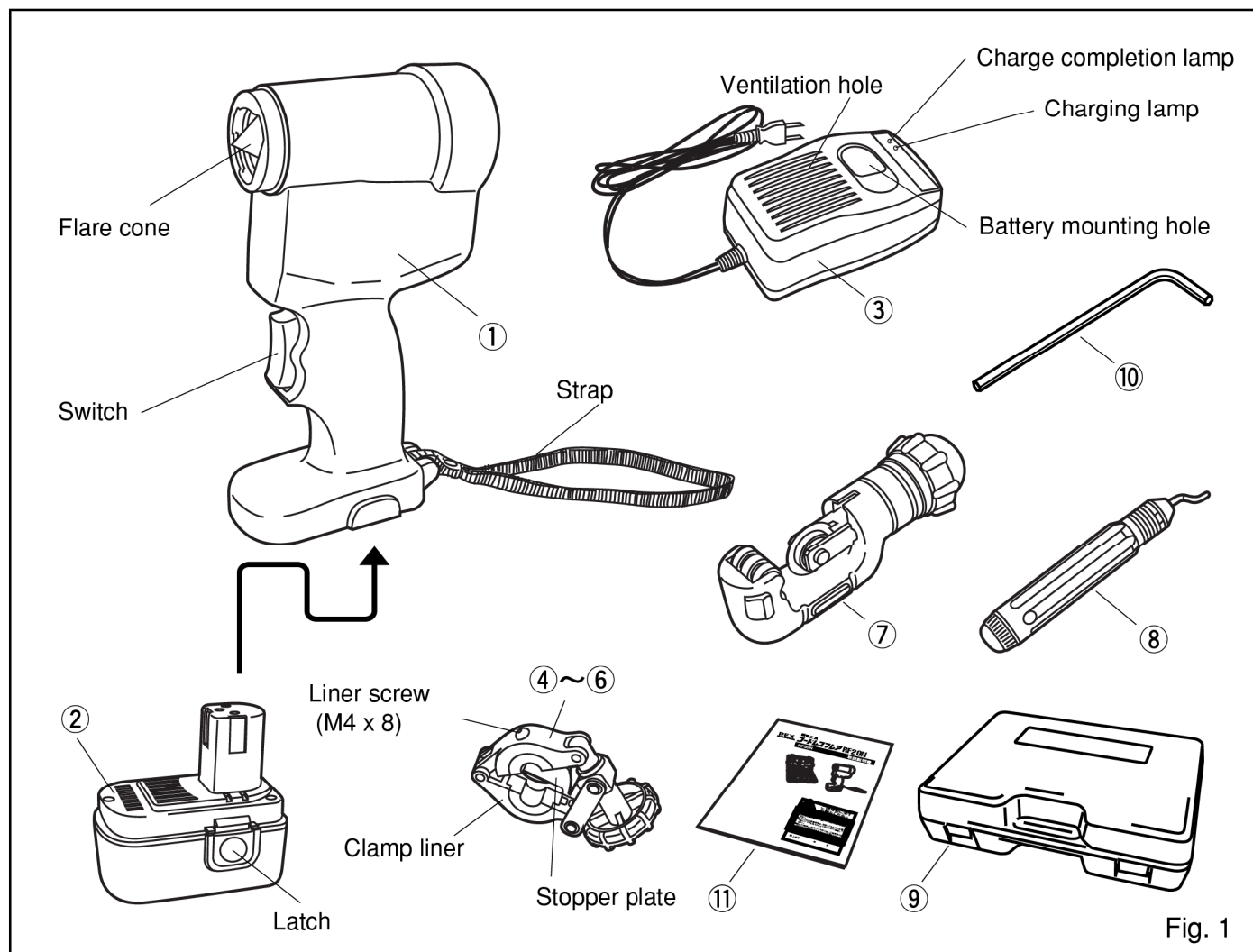

Fig. 1

## Standard Specifications (Dimensions and Weight)

	Product name	Dimensions (W x D x H mm)	Weight (g)	Quantity
1	Flaring tool (when the battery is attached)	1 2 2 x 6 7 . 5 x 2 2 4 (1 2 2 x 6 7 . 5 x 2 7 4)	1 2 7 0 (1 7 1 0)	1
2	Battery	1 0 1 x 6 3 x 9 6	4 4 0	1
3	Charger	1 6 6 x 9 4 x 7 5	1 3 3 0	1
4	Clamp for 1/4	8 4 x 8 4 x 4 5	Approx. 350	1
5	Clamp for 3/8			1
6	Clamp for 1/2			1
7	RB tube cutter ( $\phi 5$ to 32)	1 5 0 x 6 2 x 4 8	3 5 0	1
8	Scraper	$\phi$ 2 4 x 1 4 5	4 0	1
9	Carrying case	4 9 5 x 3 7 0 x 1 0 2	2 0 0 0	1
Total			6 4 8 0	

Table 1

# Names of Parts/Standard Specifications/Standard Accessories

## ■ Standard Specifications

### (1) Flaring tool

Applicable pipe	Copper tube (O/OL material)					
Applicable pipe size	Nominal diameter	1/4	3/8	1/2	5/8*	3/4*
	Outer diameter	6.35	9.52	12.70	15.88	19.05
	*(Clamp liners for 5/8 and 3/4 diameter tubes sold separately.)					
Flaring shape	Complies with shapes described in JIS B 8607. (To be referred to separately.)					
Processing method	Eccentric cone (constant-pressure plunge rotation)					
Cone speed (rpm)	280 rpm					
Power	d. c. motor					
Battery potential for flaring	Approximately 100 tube ends per fully charged battery. (may vary depending on usage.)					
Processing time	Approximately 5 seconds.					

Table 2

### (2) Battery

Battery type	Nickel cadmium
Voltage	9.6V d. c.
Capacity	2000mAh
Charging time	Approximately 60 minutes (may vary depending on usage.)
Battery rechargeability	Up to 500 times (may vary depending on usage.)
Charging temperature	5~40°C

Table 3

### (3) Charger

Applicable battery	Nickel cadmium 9.6V d. c.
Power supply	AC 220~240V (50/60 Hz)
Charging mode	Temperature control
Charging voltage	11.6V
Charging current	2400 mA
Operating temperature	5~40°C

Table 4

## ■ Standard Accessories

	Name	Quantity
1	RF20N flaring tool	1
2	Battery	1
3	Charger	1
4	Clamp for 1/4 (with liner)	1
5	Clamp for 3/8 (with liner)	1
6	Clamp for 1/2 (with liner)	1
7	RB tube cutter (φ5 to 32)	1
8	Scraper	1
9	Carrying case	1
10	Hexagonal bar spanner (Opposite side: 2.5 mm)	1
11	Operation Manual	1

Table 5

# Operating Instructions

## Preparations before use

### (1) Charging the battery

- ① Remove the battery from the main unit by pressing the latch on the battery. (Fig. 2)
  - Hold the main unit firmly and remove the battery.
  - When the flaring tool loses power, recharge the battery. If the battery is completely drained, it may not be possible to fully-recharge it, resulting in shortened battery life.

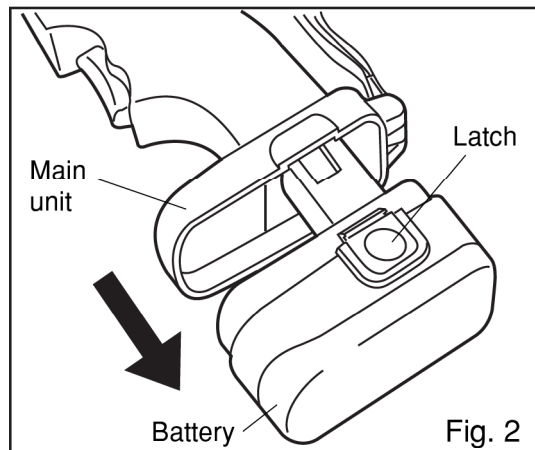

- ② Attach the battery to the battery mounting hole of the charger. Be sure to insert the battery fully into the hole. (Fig. 3)
  - Make sure the battery is aligned correctly.
  - Charge the battery within a temperature range of 5 to 40°C. Charging the battery outside this range may cause the battery to leak or become abnormally hot. In addition, the performance and the life of the battery may be adversely affected.

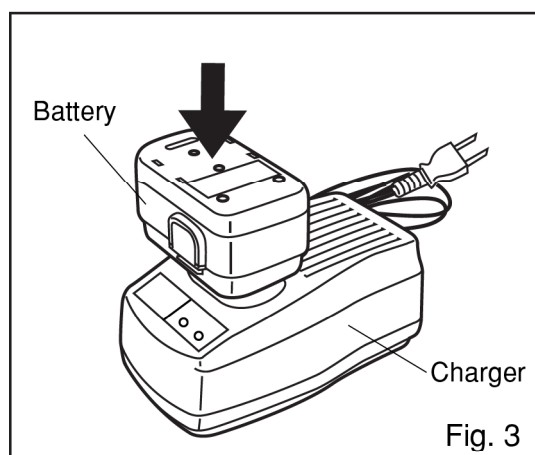

- ③ Plug the charger into the power source. The red charging lamp comes on, and charging starts. When the green charge completion lamp comes on, charging is complete. It takes about 60 minutes to complete charging. (Fig. 4)
  - The input voltage for this charger is AC220 V (50/60 Hz).
  - If you intend to charge another battery, leave the charger to cool for at least 15 minutes before charging the next one.
  - When the temperature of the battery is too high, recharging is not possible. (The green charge completion lamp will come on erroneously when a battery that is too hot is placed on the charger.)

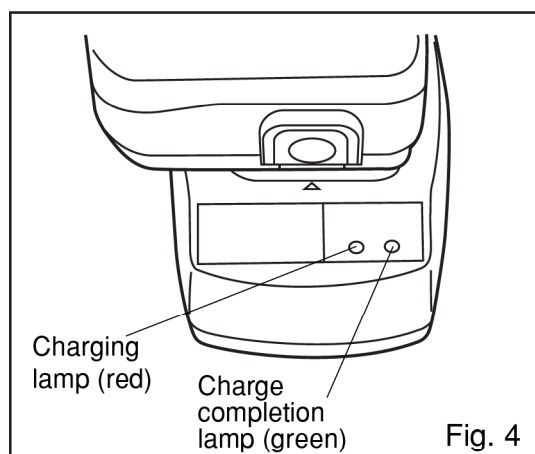

- ④ Remove the battery from the charger, and then attach it to the main unit. (Fig. 5)
  - If the battery cannot be fully recharged even after following the correct procedure, the battery life may have run out. Charging the same battery as is may damage the charger.

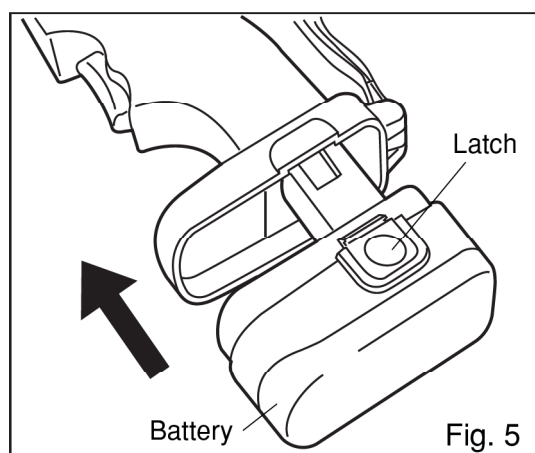

# Operating Instructions

## (2) Cutting and scraping the tube

- ① Mark a line where you wish to cut the tube, and then place the tube on the cutter. (Fig. 6)

- Tighten the cutter so that the blade lightly presses against the tube.

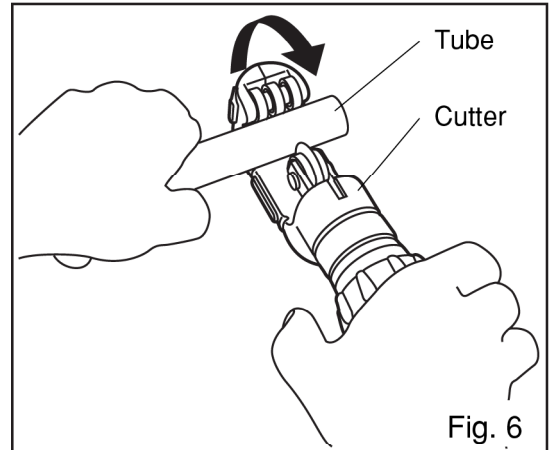

- ② Rotate the cutter around the tube in the direction of the arrow (Fig. 6) while feeding the blade by turning the knob little by little.

- When feeding the cutter blade, the knob should be turned at a rate of approximately one eighth of a rotation per one to three rotations of the tube cutter.
- If you feed the blade too quickly, the tube may be deformed and the tube cannot be flared properly. (Fig. 7)
- When you use a tube without first cutting it, check that the tube is not deformed. (Fig. 7)

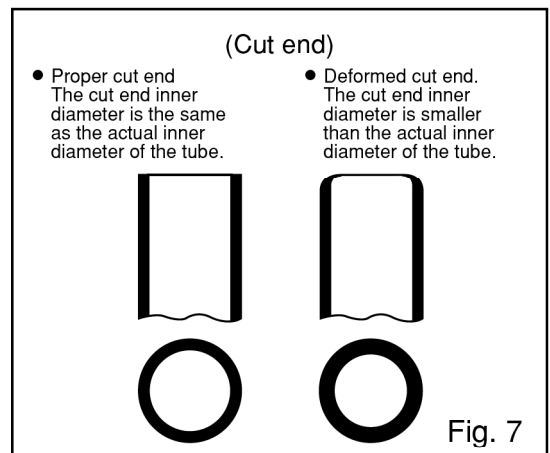

- ③ Remove burrs from the cut end of the tube with a scraper. (Fig. 8)

- Hold the cut end facing downward so that metal chips do not fall into the tube.
- If the cut end has not been properly scraped, the tube cannot be flared properly, and a gas leak may result.
- Do not make any scratches on the inner surface of the tube to be flared. Damage or scratches may remain even after the tube is flared.

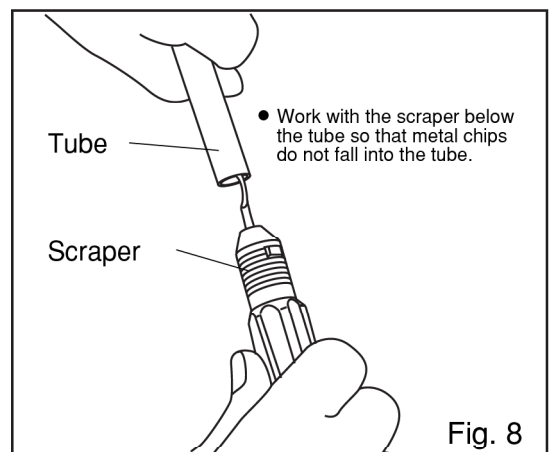

## Making a flare

### (1) Clamping the tube

- ① Slide a flare nut that is compatible with the tube size over the tube. (Fig. 9)

- Be careful of the orientation of the nut.
- Confirm that there are no burrs left on/in the copper tube.

Note that if any burrs remain, the surfaces that are flared may become dented and cause a gas leak.

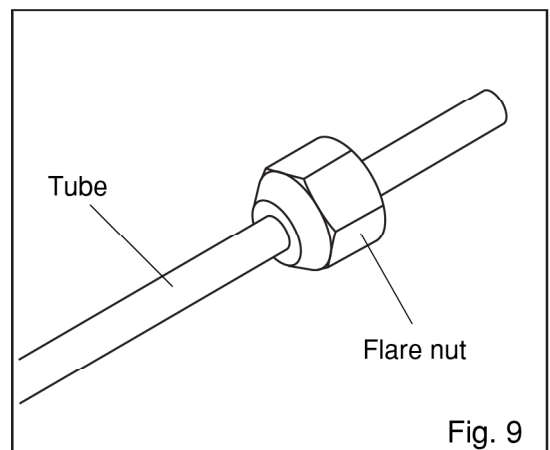

# Operating Instructions

- ② Choose a clamp that is compatible with the tube size, and then place the tube so that the tube end contacts the stopper plate. (Fig. 10)
- If there is a space between the tube and the stopper plate, the resulting flaring diameter will become smaller.
  - By turning the knob in either direction of the arrow, the clamp can immediately be opened or closed.
  - Remove any metal chips from the liner, the flare cone and the tube.

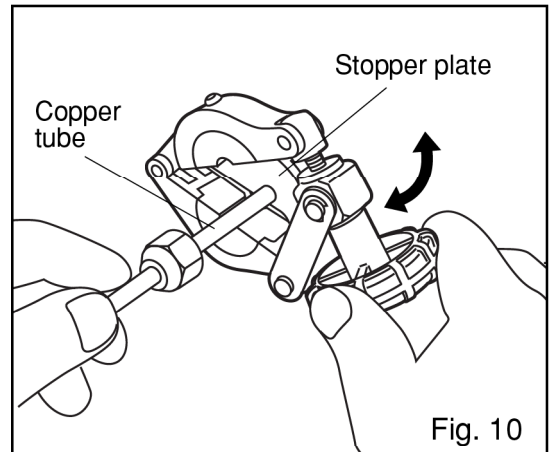

- ③ When the liner is replaced to change sizes, be sure to fit the new liner properly in the clamp before securing it with the socket bolt. (Fig. 11)
- Secure the clamp to the liner using the hexagonal bar spanner provided (2.5 mm) and hexagonal socket bolt (M4x8).

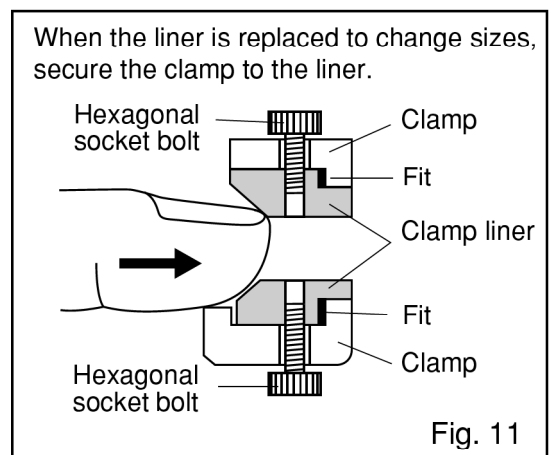

- ④ Check that the tube is placed correctly, and then clamp the tube. (Fig. 12)
- To confirm that the stopper plate is in perfect contact with the tube, try to raise the stopper plate slightly with your finger. If the stopper plate is easy to shift, it implies that there is a space between the stopper plate and the tube, so reset the tube.
  - Turn the clamp knob until the clamps are closed firmly.
  - The distance between the liners is set slightly shorter than the external diameter of the tube so that the tube will not become loose or slip. Therefore, when clamping the tube, the exterior of the tube will be scratched, but this will not pose any problem.
  - When the knob is hard to turn, apply oil or grease to the points shown on the right. (Fig. 13)

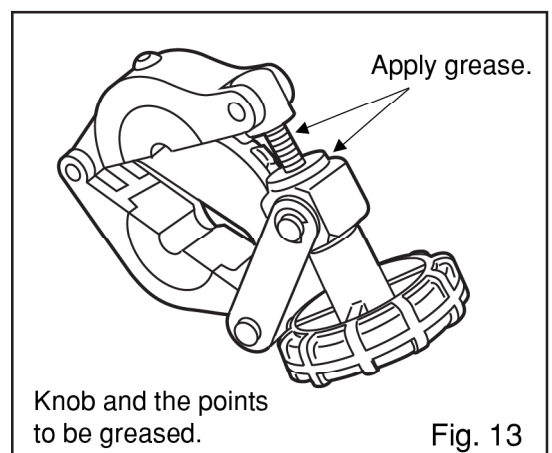
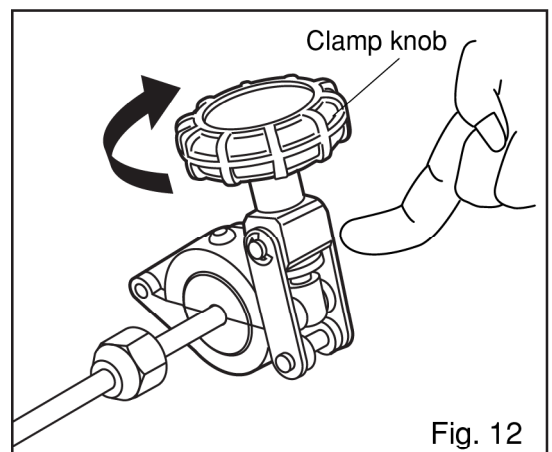

# Operating Instructions

## (2) Flaring

- ① Attach the clamp (with the tube already in place) to the main unit. (Fig. 14)
  - Attach the clamp to the main unit by aligning the tabs on the clamp with the recesses in the main unit, and then turn the main unit in the direction of the arrow until you hear a click. (Fig. 15)
  - The clamp can be set on the main unit only when the flare cone (on the main unit) is fully-retracted. If the flare cone is sticking out, press the lower part of the switch to put it in the retracted position. When you hear a clank (from the clutch), indicating that the flare cone is fully-retracted, return the switch to its original position. (Fig. 16)
  - Remove any foreign matter (metal chips, etc.) from the flare cone.  
Not removing the foreign matter could cause scratches on the inner surface of the flare, or a gas leak.

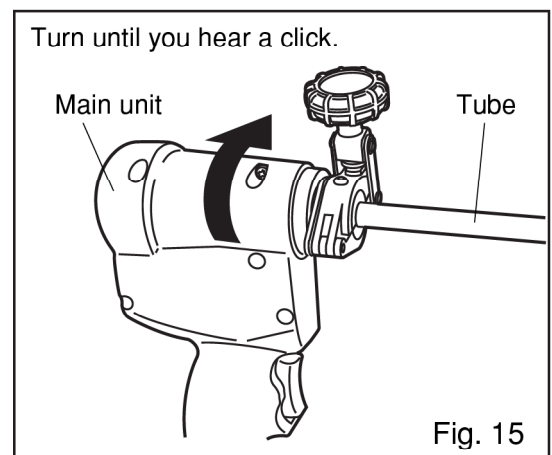
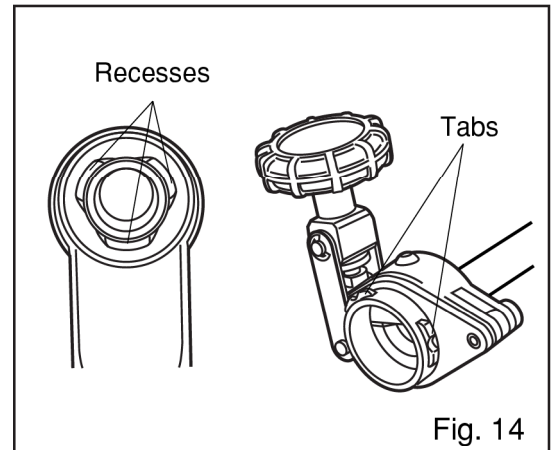

- ② Start flaring by pressing and holding the upper part of the switch. Flaring will be completed within 3 seconds from when you hear a clank (from the clutch).  
Release the switch to stop the rotation. (Fig. 16)
  - If the time for idling (from when the clutch starts operating until you release the switch) is too short, it may sometimes result in insufficient flaring.

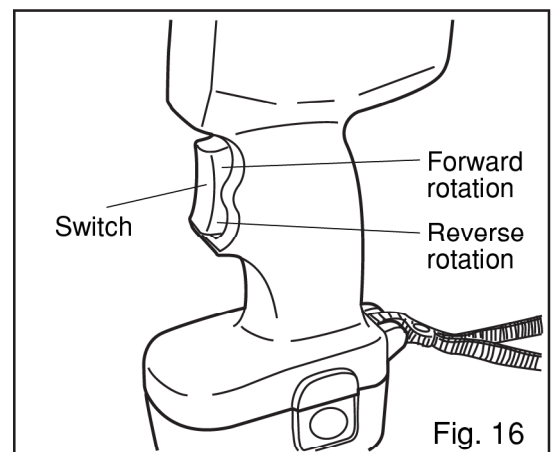

- ③ Press and hold down the lower part of the switch. The flare cone will be retracted while rotating in reverse.  
When the flare cone is fully retracted, you will hear a clank. Return the switch to its original position. (Fig. 16)
  - When the battery is on the verge of running out, flaring will exhaust the power for reverse rotation, thus preventing the flare cone from returning to its retracted position. Therefore, be sure to recharge the battery before it becomes weak.

# Operating Instructions

## (3) Removing the tube

- ① Detach the clamp from the main unit by reversing the steps for installation. (Fig. 17)
  - The clamp cannot be removed unless the flare cone is fully retracted. Avoid removing it forcibly, otherwise the flaring tool may be damaged.
- ② Loosen the knob to open the clamp, and then remove the tube. (Fig. 18)

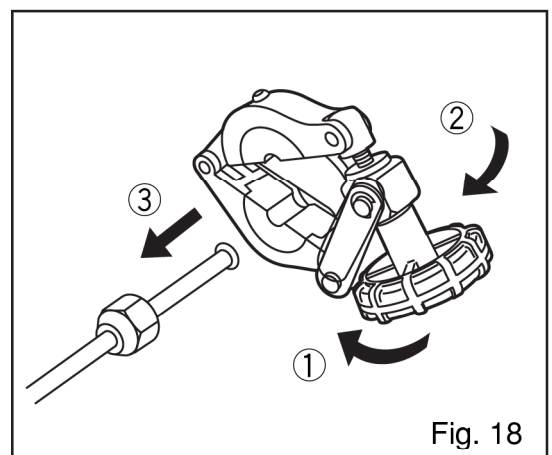
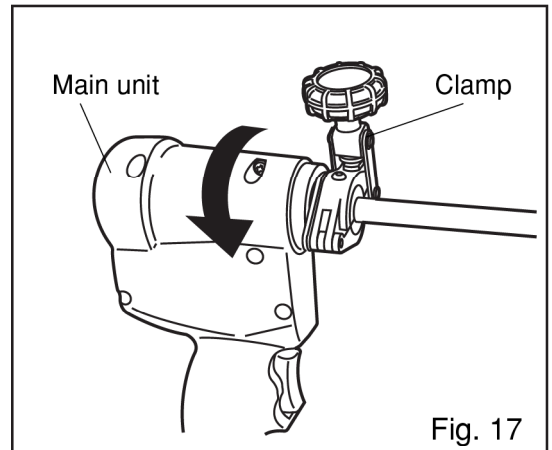

# Regular Maintenance and Inspection

## CAUTION

- Before inspection or maintenance, be sure to turn OFF the switch and also remove the battery from the flaring tool. If the battery is not removed, the tool may activate unexpectedly, causing serious injury.
- When an abnormality is found during inspection or maintenance, identify the problem referring to the descriptions in “Before asking for repairs or services” and then follow the relevant instructions. Using the product as is (without correcting the abnormality) may generate heat, fumes, or fire, causing serious accidents or injury.

### 1. Check all screws

Check all screws for looseness on a regular basis and tighten any that are loose. Continuing to use the product if any screws are loose can be dangerous.

### 2. Keep the surface clean

Clean the outside of the charger with a dry, soft cloth or with a cloth dampened in soapy water. Do not use chlorine-based solvents, gasoline or paint thinner as they may dissolve the plastic.

### 3. Store properly after work

After the job is finished, store the product in a dry place where the temperature does not exceed 40°C and with the battery separated from the charger. Keep out of the reach of children.

## Requesting repairs

This machine is produced with great precision; therefore, should the machine fail to operate normally, do not repair it by yourself, but call us for repairs.

If parts are required or if you have any questions, please contact us at your earliest convenience.

### Availability of Replacement parts

Replacement parts are maintained for a period of 7 years after production of this model has been terminated. Electrical parts, however, will remain available for a period of 5 years.

# Before Asking for Repairs or Servicing

If the product behaves abnormally, check the following and then contact the manufacturer or the sales agent from whom you purchased the product.

 CAUTION
<p>If there are no descriptions (including instructions) regarding the problem in question in the following troubleshooting table, never try to disassemble or repair the product by yourself.</p> <p>If any problems are not dealt with below or if there is any instruction that indicates repair or servicing, be sure to contact the manufacturer or the sales agent from whom you purchased the product.</p> <p>If the product is repaired by personnel without the proper knowledge or skills to repair this product, it may cause serious accidents or injury, as well as adversely affecting the performance of the product.</p>

## ■ Troubleshooting

Problem	Possible causes	Corrective measures
The flaring diameter is too small.	The tube end was pinched due to feeding the blade too quickly when the tube was cut.	Feed the cutter blade slowly to cut the tube. (Refer to page 8.)
	Burrs were left on the tube end.	Remove the burrs. (Refer to page 8.)
	There was a space between the tube end and the stopper plate.	Place the tube taking care not to leave a space between the tube end and the stopper plate. (Refer to page 9.)
	The idling time from when the clutch started operating was too short.	Make the idling time longer. (Refer to page 10.)
	Flaring pressure is diminished.	Ask for inspection or repairs. (Refer to page 12.)
Ring-shaped flaws occur on the flared inner surface of the tube. (If the flaws are shallow, this does not pose a problem.)	A large burr was on the pipe end. Remove the burrs. (Refer to page 8.)	Remove the burrs. (Refer to page 8.)
	The idling time from when the clutch started operating was too short.	Make the idling time longer. (Refer to page 10.)
	Flaring pressure is diminished.	Ask for inspection or repairs. (Refer to page 12.)
Flaws other than ring-shaped ones (vertical flaws, dents, etc.) occur on the flared inner surface of the tube.	Flaws were made while removing burrs on the inner surface of the tube.	Remove the burrs without making any flaws on the inner surface of the tube. (Refer to page 3.)
	Dust or metal chips adhered to the flare cone or the inner surface of the tube.	Remove dust and metal chips. (Refer to page 8.)
	Flaring pressure is diminished.	Ask for inspection or repairs. (Refer to page 12.)
A larger step (0.3 mm or more) occurs on the flared exterior surface of the tube.	The liner was attached in a stepped way.	Attach the liner without steps. (Refer to page 9.)
	There was a step (0.3 mm or more) on the clamp surface where the liner was to be installed.	Ask for inspection or repairs. (Refer to page 12.)
The flaring tool does not operate even when the switch is turned ON.	The battery has run out.	Recharge the battery. (Refer to page 7.)
	There are insulators, such as dust, between the battery and the conductive part of the flaring tool.	Remove the insulators.
	The wiring or the motor is faulty.	Ask for inspection or repairs. (Refer to page 12.)
The red charging lamp on the charger does not light up. (Charging is not possible.)	There are insulators, such as dust, between the battery and the conductive part of the flaring tool.	Remove the insulators.
	The wiring or the motor is faulty.	Ask for inspection or repairs. (Refer to page 12.)
	The temperature of the charger is too high.	Cool the charger and then recharge the battery. (Refer to page 7.)

Table 7

# Special Accessories

## (1) Clamp (Fig. 22)

Part No. 424950

Although it is possible to cope with different tube sizes by replacing just the liner with an appropriate one, we recommend you flare 5/8 or 3/4 diameter copper tubes using a clamp with a suitable liner as one set.

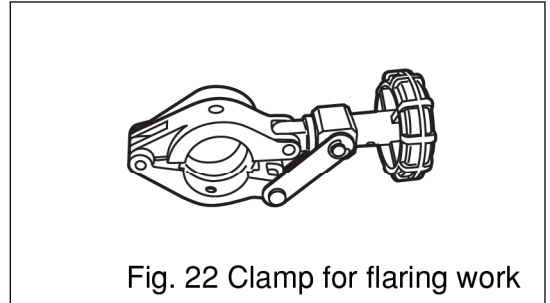

Fig. 22 Clamp for flaring work

## (2) Liners for tubes 5/8 and 3/4 in diameter (Fig. 23)

(Same as conventional ones.)

Name of Part	Part No.
New refrigerant type-2 liner 5/8 (15.88 mm)	424854
New refrigerant type-2 liner 3/4 (19.05 mm)	424855

These liners are used for 5/8 and 3/4 copper tubes, respectively.

Purchasing a liner together with a clamp as a set saves labor when replacing liners.

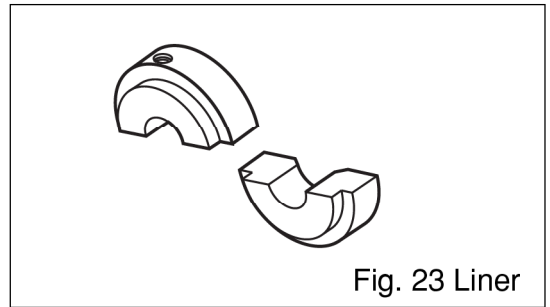

Fig. 23 Liner

## (3) NiCd battery (Fig. 24)

Part No. 424955

For your convenience, keep a spare battery.

No other manufacturer's battery can be used.

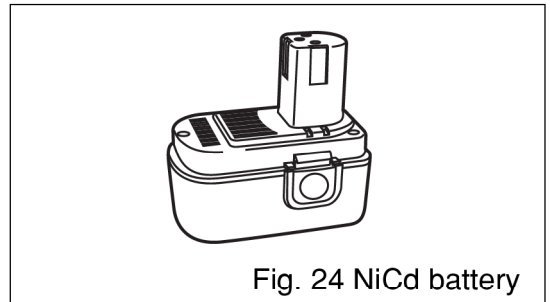

Fig. 24 NiCd battery

## (4) Charger (Fig. 25)

Part No. 424960

No other manufacturer's charger can be used.

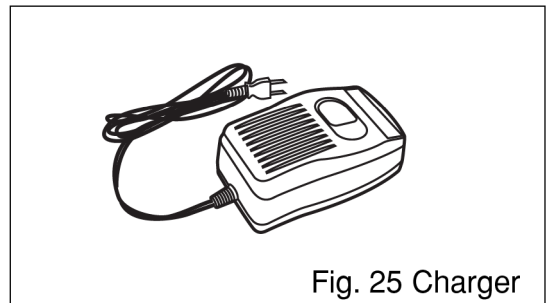

Fig. 25 Charger

## (5) Carrying case (Fig. 26)

Part No. 424957

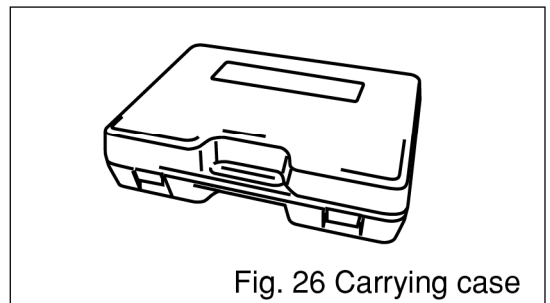

Fig. 26 Carrying case

# MEMO

# **REX INDUSTRIES CO., LTD.**

- Printed on recycled paper.
- Product specifications subject to change without notice.

RF20N-E2
0603D 0100