

Päivämäärä 15/9/2022

To the attention of:

Referenssi

Operaattori



KULMALLISET HÖYRYSTIMET - CO2
Tyyppi: FHA 28 E 80 - CO2 DX 85 Bar
Yksikköjen lukumäärä: 1

Spec. CO2 - DX

Refriger (u) 2021 Ver. 2.2.2.384 - PRICE LIST 1/5/2022

Tuleva (huone) ilman lämpötila	[°C]	4,0
Huoneen suhteellinen kosteus	[%]	85
Kylmäaine		CO2
Korkeus merenpinnasta	[m]	0
Ulkopuolinen staattinen paine	[Pa]	0
Höyrystimelle vaadittu DT 1	[K]	8,0
Liitäntä	230V-1PH-50Hz	EC FANS
Varsinainen teho	[W]	1 800
Ilmavirta	[m3/h]	1 430,0
Heittopituus	[m]	12
Lähtevän ilman lämpötila	[°C]	1,4
Höyrystymis lämpötila	[°C]	-3,5
DT Ylikuumeneminen	[K]	5,0
Lämpötila ennen ekspansiovent.	[°C]	5,0
DT1	[K]	7,5
DTmlg	[K]	6,1
Nesteen painepudotus	[K]	0,2
RC faktori (Sensitiivinen teho/totaalinen teho)	[%]	70,6
Puhallinmoottorin kulutus	[W]	34
Moottorin virran kulutus	[A]	0,28
Maksimivirta (indicative*)	[A]	0,36
Puhallin nopeus	[1/min]	1400 (Fixed speed)
Äänitaso (5 m) 5	[dB(A)@5m]	45
Äänenvoima taso	[dB(A)]	70
Sähkösulatus (230 V)	[W]	900
Puhaltimien lukumäärä	[mm] 2 x 275	Paino [kg] 17
Napaisuus	[n] EC FANS	Liitännät sisään / ulos [n] x [mm] 1 x 10
Lamelli jako	[mm] 7	Liitäntä ulos [n] x [mm] 1 x 10
Sisätilavuus	[dm3] 1,0	Tippuveden liitäntä ["] 3/4
Pinta	[m2] 5,1	Kokonaismitat [mm] 920 x 555 x 260
maks työ paine	[bar] 85,0	
Kotelo materiaali	Muoviaine Safashell valkoinen väri	Lamelli materiaali Al
Yhdystukkien materiaali	Cu	Putki materiaali Cu

* Refer to LU-VE S.p.A. instruction manuals for details, data and standards. Äänen taso 5m . Virta voi muuttua riippuen lämpötilasta, kourutuskerroksesta, ulkopuolisesta painosta. Painot ja mitat ei ole voimassa kaikille mahdollisille rakenteille Kaikki puhaltimet ovat ErP 2015-myöntöväiset (Ohjesääntö 2009/125/EC energia liittyvät tuotteet). LU-VE S.p.A. reserves the right to modify and correct at any time, with or without notice, the specifications and prices listed in the Refriger software.

The certified performances and conditions in this software are in line with performances and conditions published on EUROVENT website. Those performances can be verified in www.eurovent-certification.com.

The EUROVENT certification refers to the unit in standard configuration, additional options may impact on declared reference performance.

Lisävarusteet:

Määrä	Koodi	Malli	Selitys
2	30196987	EC FAN - 230V - 1400rpm	EC PUHALTIMET

FHA

1100 ÷ 8900 W

Angled unit-coolers for small cold rooms.

The dimensional and functional characteristics that distinguish the new super compact - super efficient unit cooler range are:

- Super efficient heat exchanger
- Reduced dehumidification
- Reduced frost formation
- Increased air throw
- Greatly reduced internal volume
- Low noise levels
- Low energy consumption
- Very compact overall dimensions

OPTIONS

EC FANS

JET-O-MATIC® distributor.

JET-O-MATIC®

Maximum unit cooler capacity at every condition of heat load, room temperature, temperature difference and refrigerant type, specially with the new refrigerants characterized by a mixture with high gas/liquid ratio after the expansion valve.

New Turbocoil 2 Heat Exchanger

Our super efficient Turbocoil 2 heat exchanger has a high ratio of capacity/cost, that has been achieved by the following:

Tubes

New small diameter inner grooved helical, high efficiency copper tubes specially developed for the new refrigerants.

Turbofin 2

New aluminium high efficiency fins with special turbulence, reducing dehumidification and frost formation.

Fin Spacing

To satisfy all refrigeration requirements in High, Medium and Low temperature application and in different humidity conditions three new ranges of unit coolers are available

Range **32** = Fin spacing 3,1 mm

Range **50** = Fin spacing 4,8 mm

Range **80** = Fin spacing 7,7 mm

Distributor and Refrigerant Circuit

Distributors and refrigerant circuits optimised to ensure maximum efficiency of the heat exchanger in various applications of the unit cooler.

STANDARD: Venturi distributor.

OPTION: **JET-O-MATIC**® distributor.

Suction pressure gauge connection

This allows for the checking of suction pressure and correct performance of the unit cooler.

Fan Motor Assembly

All models use a new type of high efficiency low consumption fan motor assembly, incorporating internal thermal protection. The fans have been statically and dynamically balanced, fan motor assembly are wired to the unit's electrical box.

275 mm diameter motor assembly

Voltage 1ph 230V 50/60Hz

Insulation class F

Protection IP 44.

Electrical box

Protection IP 55.

Fan Shroud and Grille

Special attention has been given to the air flow path to provide uniform and aerodynamic air flow through the coil. All fan guards conform to the most severe European Safety Standards, thus guaranteeing maximum protection.

Electric Defrost

The stainless steel electric heater element permits a quick and efficient defrost of the coil. The heater elements are connected to the unit's electrical box.

Electrical box

Protection IP 54.

Casing

Fan guards, shrouds and side casing are manufactured in a white reinforced material which is suitable for use in low temperature coldrooms.

Maintenance and Cleaning

Access to all internal parts can be achieved with one tool. The casing is easily removable to give all round accessibility and to make installation, cleaning or service much easier than traditional unit coolers.

The units are EUROVENT certified

Design standard

The products are provided for incorporation in machines as defined in the EC Machine Directive **89/392/EEC** and subsequent modifications according to the following safety standard references:

- **EN 60/335-1 (CEI 61-50)** Safety of household and similar electrical appliances. General requirements.
- **CEI-EN 60/335-2-40** Safety of household and similar electrical appliances - Part 2: Particular requirements for electrical heat pumps, air conditioners and dehumidifiers.
- Machine Directive **89/336 EEC** and subsequent modifications. Electromagnetic compatibility.
- Directive **73/23 EEC** Low tension.
- **EN 294** Fan guards.

Quality Assurance

LU-VE is a certificated company to UNI EN ISO9001:2000, which is the most important Quality Assurance qualification, covering Development, Testing, Production method and Inspection procedures.

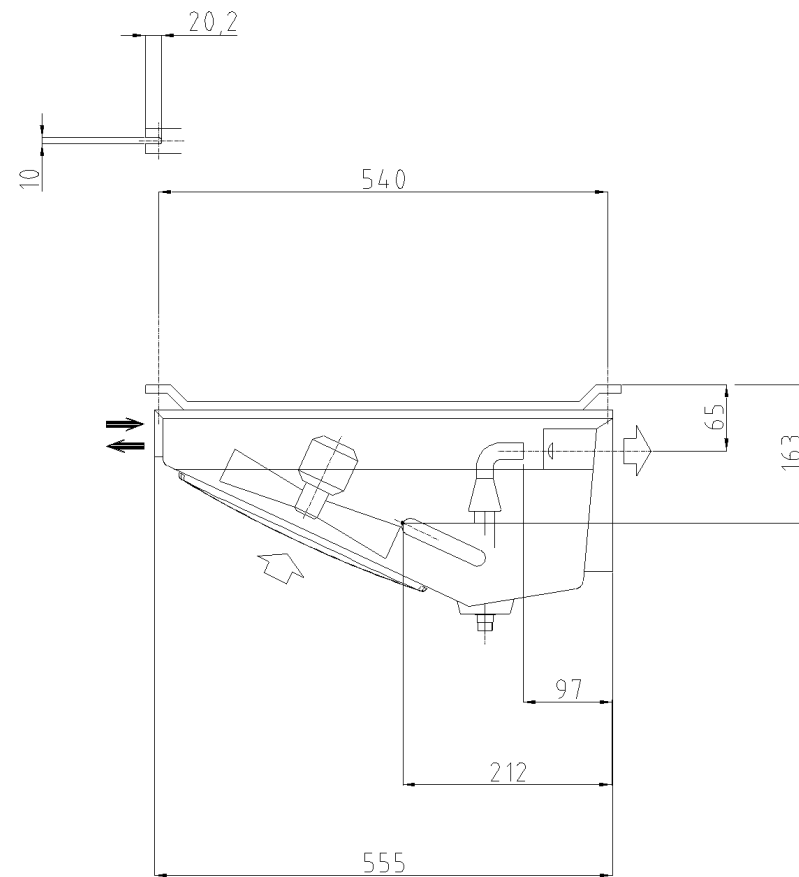
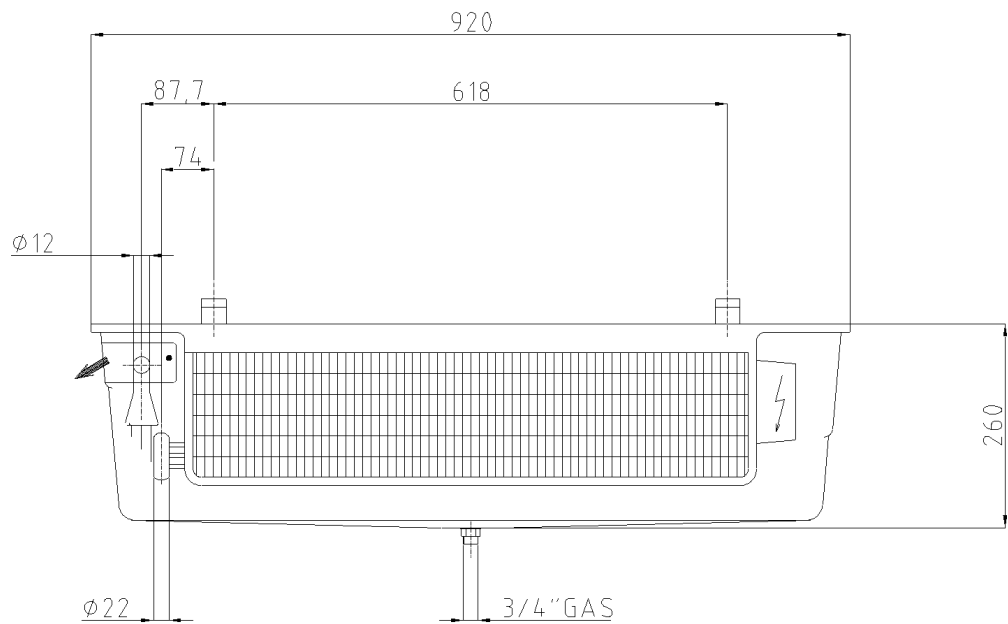

Date	06-08-2015	Type: FHA 28 E 80 - CO2 DX 85 BAR
Scale	1:1	Code: 10150428